

Z.I de KERANDRE - RUE GUTENBERG

56700 HENNEBONT - FRANCE

Telephone: +33 (0)2 97 36 10 12 Fax: +33 (0)2 97 36 55 17

Web : <http://www.nke.fr> - E-mail : info.instrumentation@nke.fr

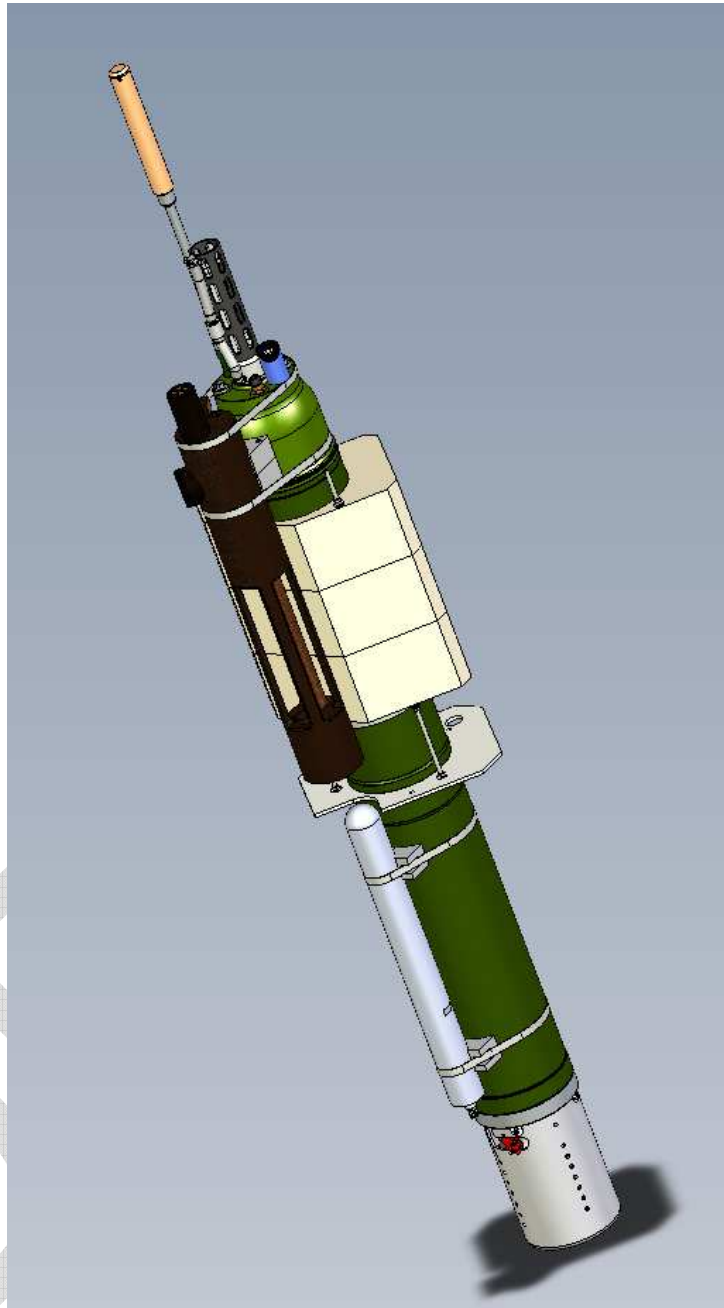

USER MANUAL

© nke: This document is the property of **nke electronics** and contains proprietary and confidential information. The document is loaned on the express condition that neither the document itself nor the information contained therein shall be disclosed without the express consent of **nke electronics** and that the information shall not be used by the recipient without prior written acceptance by **nke electronics**. Furthermore, the document shall be returned immediately to **nke electronics** upon request.

DOC du 14 / 12 / 2017 rev.10 draft 6

DRAFT 6

1	INTRODUCTION	8
2	OPERATING INSTRUCTIONS.....	9
2.1	HANDLING PRECAUTIONS.....	9
2.2	ACCEPTANCE TESTS	9
2.2.1	<i>Inventory.....</i>	9
2.2.2	<i>Physical Inspection.....</i>	9
2.3	DEFAULT PARAMETERS.....	9
2.3.1	<i>ARGO Identification.....</i>	9
2.3.2	<i>Decoding</i>	9
2.4	LAUNCHING.....	10
2.4.1	<i>Test the Float and arm the mission</i>	10
2.4.2	<i>Remove protective plugs and magnet</i>	10
2.4.3	<i>Deployment checklist.....</i>	12
2.4.4	<i>Launch the Float</i>	13
2.5	CHECKS PRIOR TO DEPLOYMENT.....	14
2.5.1	<i>Necessary Equipment</i>	14
2.5.2	<i>Connecting the PC.....</i>	15
2.5.3	<i>Example of Bluetooth dongle tested by NKE.....</i>	17
2.5.4	<i>How to Send Commands.....</i>	17
2.5.5	<i>How to Read and change Parameter Values.....</i>	18
2.5.6	<i>How to Check and change the Time</i>	21
2.5.7	<i>Configuration Check</i>	21
2.5.8	<i>Functional Tests</i>	22
3	GENERAL DESCRIPTION OF PROVBIIOII FLOAT.....	29
3.1	PROVBIOII (CTS4 BASE)	29
3.1.1	<i>Electronics.....</i>	29
3.1.2	<i>Embedded software</i>	29

DRAFT

DRAFT 6

3.2	DENSITY CONTROL SYSTEM	31
3.3	SENSORS	31
3.4	IRIDIUM TRANSMITTER	31
3.5	CPU BOARD	31
3.6	MEASURE BOARD	31
3.7	BATTERY	31
3.8	MMI LINK	31
3.9	FIRMWARE EVOLUTIONS	32
4	THE LIFE OF AN PROVIOII FLOAT	33
4.1	THE MISSION - OVERVIEW	33
4.2	DESCENT	35
4.3	GROUNDING	35
4.4	SUBMERGED DRIFT	36
4.5	ASCENT	36
4.5.1	<i>Ice detection (with firmware V3.00 and higher)</i>	36
4.6	MULTI-PROFILES	37
4.7	TRANSMISSION	37
5	PROVBIOII PARAMETERS	38
5.1	MISSION PARAMETERS	38
5.1.1	<i>Mission Parameters details (PM)</i>	40
5.2	VECTOR PARAMETERS (PV)	42
5.2.1	<i>Vector Parameters details</i>	44
5.3	SENSOR PARAMETERS (PC)	45
5.3.1	<i>How to read and modify Sensor Parameter</i>	45
5.3.2	<i>Standard parameter information</i>	46
5.3.3	<i>Specific parameter information</i>	49
5.3.4	<i>CTD parameters (Sensor "0")</i>	49
5.3.5	<i>Optode Parameters (Sensor "1")</i>	53
5.3.6	<i>OCR504 Parameters (Sensor "2")</i>	55
5.3.7	<i>ECOFL Parameters (Sensor "3")</i>	57
5.3.8	<i>FLNTU Parameters (Sensor "4")</i>	59
5.3.9	<i>CROVER Parameters (Sensor "5")</i>	61
5.3.10	<i>SUNA Parameters (Sensor "6")</i>	63
5.4	ICE PARAMETERS (WITH FIRMWARE V3.00 AND HIGHER)	65
5.4.1	<i>ICE parameters description</i>	65
5.5	RUDICS PARAMETERS	66
5.5.1	<i>Transmission strategy</i>	68
5.5.2	<i>Telecommands file</i>	68
5.5.3	<i>Retries strategy (unavailable with firmware V3.00 and higher)</i>	68
5.5.4	<i>How to read Rudics parameter</i>	69
6	USER COMMANDS	70
7	IRIDIUM FORMATS	72
7.1	TRANSMISSION STRATEGY	72
7.2	PACKET STRUCTURE	74
7.3	PACKET TYPES	74
7.3.1	<i>Sensor Data type</i>	74
7.3.2	<i>Phase description</i>	76
7.3.3	<i>Coding format</i>	76
7.3.4	<i>Packets Formats</i>	77
7.4	LIFE EXPIRY MESSAGES	109
7.5	PACKET TRANSMITTING SEQUENCE (IRIDIUM SESSION)	109
7.6	IRIDIUM COMMMANDS	109
7.6.1	<i>Command Sending procedure (SBD MODE)</i>	110
8	SPECIFICATIONS	112
9	PROVBIOII OPERATING PRINCIPLE	113

10 LITHIUM BATTERY.....114
11 GLOSSARY115

DRAFT 6

DATE	REVISION	OBJET	Auteur
20/07/12	0	Création (prototype)	JS
15/01/12	1		JS
06/03/13	2		JS
04/09/13	3		JS
21/01/14	4		JS
14/02/14	5		DN
15/05/14	6		JS
02/09/14	7		JS
28/08/15	8		DN
18/12/15	9		JS
08/08/17	10		JS/DN
17/10/17	10 Draft 3	Correction on packet number 253	DN
07/11/17	10 Draft 4	Add ECO2 decoding + correction on pressure offset for packets 0	DN
14/12/17	10 Draft 5	Correction of Free zone decoding of sensor OCR	DN
23/02/18	10 Draft 6	Add packet number 248 description	DN

DRAFT

1 INTRODUCTION

ProvBioll is a subsurface profiling float developed jointly by IFREMER and NKE. It is also called PROVOR CTS4.

The ProvBioll float described in this manual is designed for the ARGO Program. This international program will be a major component of the Global Ocean Observing System (GOOS). An array of 3,000 free-drifting profiling floats is planned for deployment in 2004. These floats will measure the temperature and salinity of the upper 2,000 meters of the ocean, allowing continuous monitoring of the ocean's climate.

All Argo measurements will be relayed and made publicly available within hours after collection. The data will provide a quantitative description of the evolving state of the upper ocean and the patterns of ocean climate variability, including heat and freshwater storage and transport. It is expected that ARGO data will be used for initialization of ocean and coupled forecast models, and for dynamic model testing. A primary focus of Argo is seasonal to decadal climate variability and predictability.

After launch, ProvBioll's mission consists of a repeating cycle of descent, submerged drift, ascent and data transmission. During these cycles, ProvBioll dynamically controls its buoyancy with a hydraulic system. This hydraulic system adjusts the density of the float causing it to descend, ascend or hover at a constant depth in the ocean. The user selects the depth at which the system drifts between descent and ascent profiles. ProvBioll continually samples the pressure at this drift depth and maintains that depth within approximately +/-50m.

After the submerged drift portion of a cycle, the float proceeds to the depth at which the ascending profile is to begin. The ascent profile starting depth (typically the ARGO-selected depth of 2,000m) is not necessarily the same as the drift depth.

During its mission, ProvBioll collects measurements of several parameters (depending on sensor mounted) - salinity, temperature, depth, and optional measurement : dissolved oxygen, Chlorophyll A, CDOM, Backscattering, Nutrients, ... - and saves them in its memory. These measurements can be sampled during the float descent (descent profile), during the submerged drift period (Lagrangian operation) and during the ascent (ascent profile).

After each ascent, ProvBioll transmits its saved data to the satellites of the Iridium system.

This manual describes the ProvBioll float, how to use it and safety precautions to be observed during handling.

Please read this manual carefully to ensure that ProvBioll functions as intended.

Overview of the present manual's contents:

- [Chapter 2](#) contains the instructions necessary for the personnel in charge of the deployment
- [Chapter 3](#) describes the components of ProvBioll ; it is intended for those who want a more in-depth understanding of ProvBioll
- [Chapter 4](#) describes the mission of ProvBioll
- [Chapter 5](#) describes the various parameters
- [Chapter 6](#) describes the user commands that can be send to the float
- [Chapter 7](#) describes the formats of the various Iridium messages
- [Chapter 8](#) presents the technical specifications
- [Chapter 9](#) provides explanations about the operation of ProvBioll
- [Chapter 10](#) specifies the elements of the constraints limited to the transport of Lithium batteries.

2 OPERATING INSTRUCTIONS

The following instructions tell you how to handle, configure, test and launch the ProvBioll float. Please read these instructions carefully and follow them closely to ensure your ProvBioll float functions as intended.

2.1 Handling Precautions

ProvBioll is designed to withstand submersion at great depths for long periods of time (up to five years). This remarkable specification in oceanographic instrumentation is possible thanks to the protection of the casing by an anti-corrosion coating. This coating is sensitive to impact. Damage to the coating can accelerate the corrosion process.

NOTE: *Take precautions to preserve the anti-corrosion coating during handling. Remove the float from its packing only when absolutely necessary.*

NOTE: *Regulations state that ProvBioll must not be switched on during transport.*

2.2 Acceptance Tests

Immediately upon receipt of the ProvBioll float, you should test it to confirm that it is complete, correctly configured and has not been damaged in shipment. If your ProvBioll float fails any of the following tests, you should contact **nke electronics**.

2.2.1 Inventory

The following items should be supplied with your ProvBioll float:

- The present user manual.
- A test sheet.

NOTE: *Disassembly of the float voids the warranty.*

Check that all of the above items are present. If any are missing, contact **nke**.

2.2.2 Physical Inspection

Upon the opening of the transport casing, visually inspect the float's general condition: Inspect the transport container for dents, damage, signs of impact or other signs that the float has been mishandled during shipping.

Inspect the CTD sensor, antenna, hull, housing around the lower bladder for dents or any other signs of damage

NOTE: *Ensure the magnet is in place against the hull (on ON/OFF position).*

2.3 Default Parameters

Notwithstanding special instructions given to NKE during the ProvBioll preparation stage, the following set of parameters is applied: [section 5](#).

If these parameters are not appropriate, the user can change them himself by following the instructions.

2.3.1 ARGO Identification

The user is responsible for contacting the AIC in order to obtain the WMO number which will identify the ProvBioll 's mission.

2.3.2 Decoding

The CORIOLIS project team (IFREMER) is able to assist the teams that use ProvBioll for data processing.

2.4 Launching

Following is what you should do to launch the ProvBioll float.

2.4.1 Test the Float and arm the mission

Before you take ProvBioll on deck for deployment, we recommend that you repeat all of the tests described in [section 2.5.8](#). This will ensure that the float is functioning and configured correctly and maximize the probability of success of your experiment.

IMPORTANT: Before launching the float, you must arm the mission by issuing the !AR 1 command:

!AR ON

ProvBioll will respond :

<AR ON>

Put the magnet on the float (ON/OFF position).

NOTE: *Once the mission is armed, the next time you will attempt to communicate with the float upon magnet removal, you need to establish Bluetooth connection (see [section 2.5.2](#)) and press "ENTER" within 30 seconds in order to get the prompt].*

2.4.2 Remove protective plugs and magnet

The pump system of the CTD sensor is sealed by 3 protective plugs. Remove these plugs from the sensor before launching.

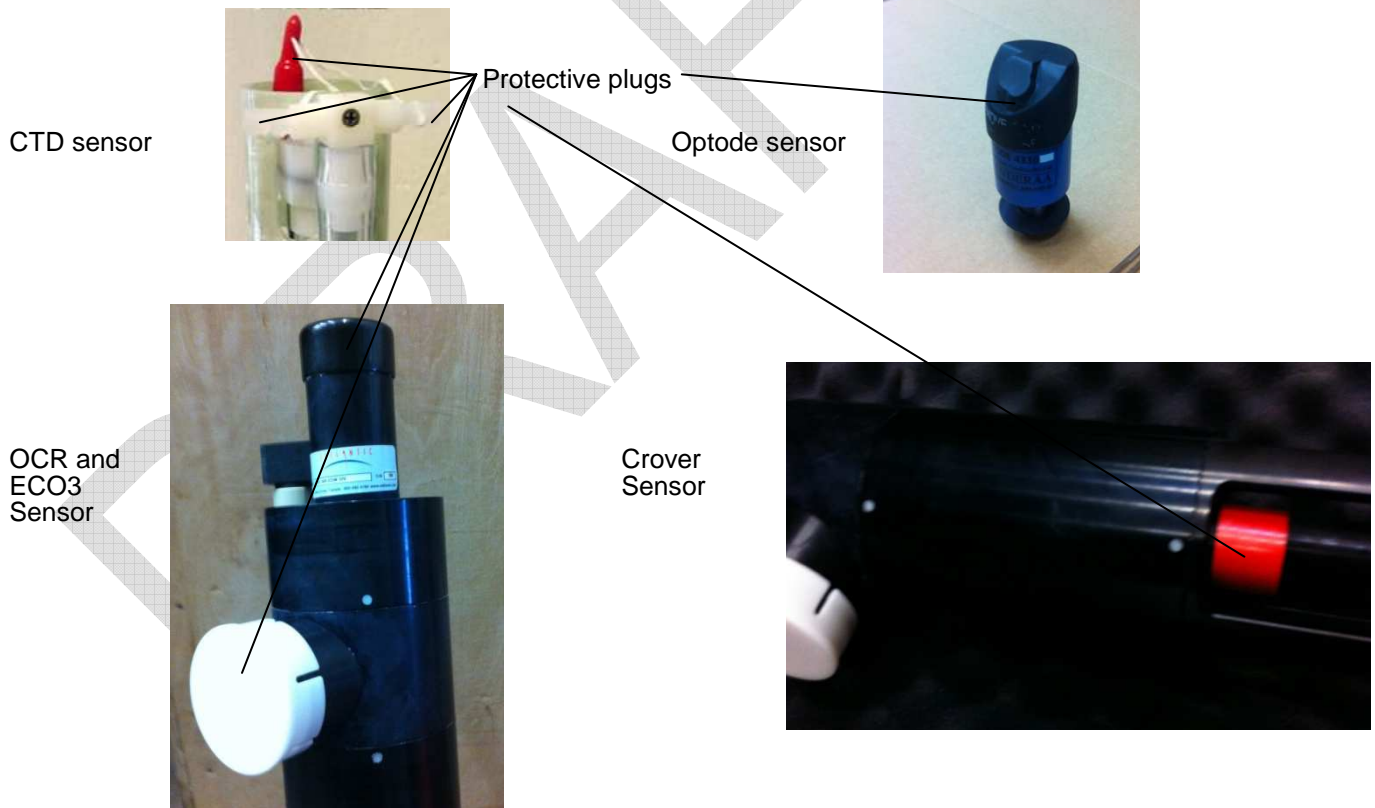

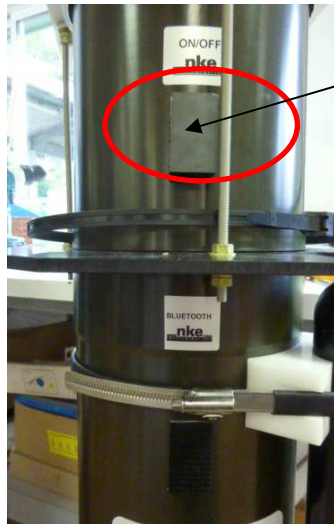

ON/OFF Position

Remove the magnet located near the top of the float (see [Figure 1](#) – General view of ProvBioll float). Retain the magnet for future use in case the float is recovered.

ProvBioll is now ready for launch.

To confirm that the magnet has been removed and that the float is ready for launch, 5 seconds after magnet removal, ProvBioll starts 5 valves actions. After 80s, the seabird pump is active. If you have water in the CTD, this water go out by the holes where was the protectives plugs. After 100 sec, floats starts 5 quick valve activations.

NOTE: *Once the magnet has been removed, the ProvBioll float performs an initial test (**if Armed Mode is ON only**). Ensure that the CTD pump starts as explained above before placing the float in the water.*

If your do not hear the valve running after 30 seconds, and you do not see the water after 90s, replace the magnet, connect the PC, and conduct the tests described in [section 2.5](#). If these tests fail, contact **nke** technical support.

2.4.3 Deployment checklist

Test	Description	Expected Result	Result
Check before deployment			
1	Visual inspection	No scratch, good general state	<input type="checkbox"/> OK
2	Magnet Position	Magnet placed on ON/OFF position (means OFF)	<input type="checkbox"/> OK
3	Remove all sensor plugs	Plugs removed (see section 2)	<input type="checkbox"/> OK
4	Distilled Water in conductivity cell	Introduce distilled water in conductivity cell (enable CTD pump check on test 5 & 8)	<input type="checkbox"/> OK
Check during deployment (Float must be <u>on VERTICAL position</u>)			
5	Magnet removal	Magnet removed from ON/OFF position	<input type="checkbox"/> OK
6	5 slow Ev activations	5 slow Ev activations heard (5-15 sec after magnet removal)	<input type="checkbox"/> OK
7	Hydraulic pump	Hydraulic pump activation to fill in external bladder (from 0 sec to several minutes depending on bladder state at deployment)	<input type="checkbox"/> OK
8	Full auto-test (see chapter 2.5.8.2 for detail about tests)	CTD pump : Water level change in CTD water circuit, Optical sensor activation (Light on ECO-FL sensor), Float acquire GPS position and rudics connection on ftp server (Iridium link). <i>This can take up to several minutes depending on satellite visibility</i>	<input type="checkbox"/> OK <input type="checkbox"/> OK
9	5 quick Ev activation	5 quick Ev activations heard	<input type="checkbox"/> OK
10	Delay before mission	Wait for " PM1 " Minutes	<input type="checkbox"/> OK
11	CTD pump	Water level change in CTD water circuit	<input type="checkbox"/> OK
12	Hydraulic pump	Hear Hydraulic pump (2 sec)	<input type="checkbox"/> OK
13	Iridium Transmission	Iridium transmission (files received on ftp server or by mail (SBD transmission))	<input type="checkbox"/> OK
Deployment			
14	Deployment	Deployment system in place	<input type="checkbox"/> OK
15	Float drift	Float drift at surface	<input type="checkbox"/> OK

If **step 9** is not reached and Iridium message are not received, place magnet on ON/OFF position and try again from beginning. To check iridium transmission & GPS acq, it is recommended to reach **step13**

Do not DEPLOY after 3 unsuccessful tries !

2.4.4 Launch the Float

NOTE: *Keep the float in its protective packaging for as long as possible to guard against any nicks and scratches that could occur during handling. Handle the float carefully, using soft, non-abrasive materials only. Do not lay the float on the deployment vessel's unprotected deck. Use cardboard or cloth to protect it.*

2.4.4.1 By hand

ProvBioll can be launched by hand from the deck from a height of 2 meters

2.4.4.2 Using a rope

The damping disk is already fastened on the tube (under the buoyancy foam).

It is possible to use the holes in the damping disk in order to handle and secure the float during deployment.

After the launch, you may decide to wait alongside the float until it starts its descent, but this can take up to 3 hours depending on the float's buoyancy when it is placed in the water.

2.5 Checks prior to deployment

2.5.1 Necessary Equipment

The equipment required to check that ProvBioll is functioning correctly and to prepare it for the mission are:

(1) A PC.

The most convenient way of communicating with ProvBioll is with a PC in terminal emulation mode. Among other advantages, this allows storage of configuration parameters and commands. You can use any standard desktop or laptop computer. The PC must be equipped with a serial port (usually called COM1 or COM2).

(2) VT52 or VT100 terminal emulation software.

The Hyper Terminal emulation software can be used.

(3) A Bluetooth Dongle with drivers installed on the PC (BELKIN class 2 model is recommended).

(4) An accurate time source.

This could be a wristwatch, a GPS receiver or the PC's internal clock. Some users use a GPS receiver connected to the PC to adjust the clock.

DRAFT

2.5.2 Connecting the PC

Make sure you check the following points before attempting a connection:

- ✓ Bluetooth key connected to the PC with the drivers installed
- ✓ Magnet present at the Bluetooth's power supply ILS (see [Figure 1 – General view of ProvBioll float](#))
- ✓ Start Hyperterminal after checking on which COM port the Bluetooth key is installed by going to: Control Panel->System-> click on Hardware tab->Device Manager as shown in the figure below:



- ✓ On the PC, run the following commands as shown in the figure below:
- ✓ Right click on the Bluetooth logo in the bottom right corner of the Desktop
- ✓ Select Quick Connect, Bluetooth Serial Port, then click on other devices



A window appears as shown in the figure below:

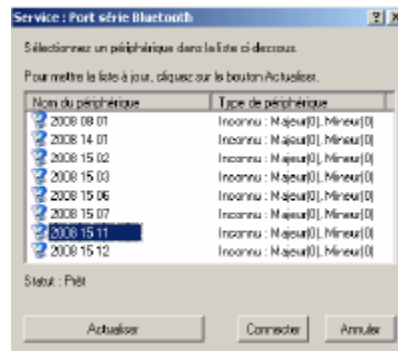

- ✓ Click on Refresh
- ✓ Check that the Bluetooth number is present on the traceability label (see [Figure 1 – General view of ProvBioll float](#))
- ✓ There are two ways of establishing the connection:
- ✓ Either select the number shown and press Connect
- ✓ Or come back to the previous step and instead of selecting “other devices”, select the number shown
- ✓ When the connection is made, a dialog box appears as shown in the figure above:



Double click on it and a window appears as shown below:

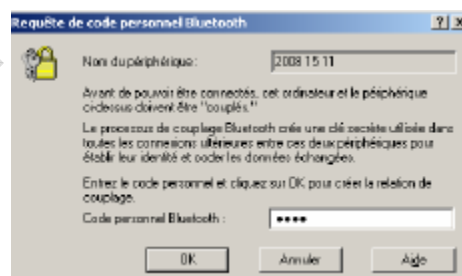

- ✓ Enter the security code “0000”
- ✓ You can now check the connection by double clicking on the Bluetooth logo in bottom right corner of the Desktop
- ✓ The “Bluetooth favourites” window appears:

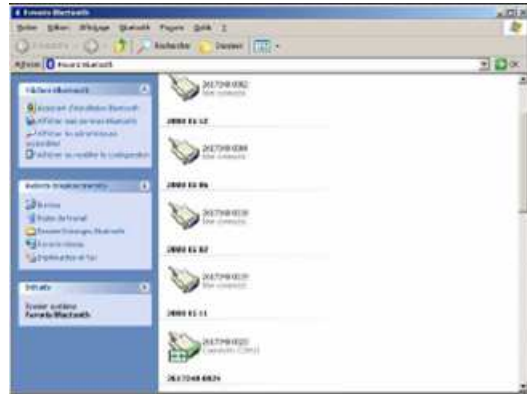

Use your PC's terminal emulation software to configure the selected serial port for:

- 9,600 baud
- 8 data bits
- 1 stop bit
- Parity: none
- Full duplex
- No flow control

2.5.3 Example of Bluetooth dongle tested by NKE



USB Bluetooth™ adaptor - 100 meters,
Part # F8T012fr
Made by Belkin

2.5.4 How to Send Commands

You must communicate with ProvBioll to verify or change its configuration parameters, to read data from the float, or to test the float's functions. You perform these verifications/changes by sending commands, and by observing the float's response to those commands. Compose commands by typing characters on the keyboard of your PC, and send them to ProvBioll by pressing the Enter key.

In the following descriptions of commands we will use the general syntax:

- Keystrokes entered by the user are written in **bold**.
- Replies received from the float are in normal font.
- Commands entered by the user end with the Enter key.

The software version can be viewed using the **?VL** command
ProvBioll will respond:

```
<ProvBioll >
<VL V1_06 >
<TX RUDICS >
Get measure ?VL
SOFTWARE VERSION Measure: V1.06
]
```

The float's serial number can be viewed using the **?NS** command
ProvBioll will respond:

```
<NS 1202>
Get measure ?NS
SERIAL NUMBER Measure: 1202
] (year 12, identification 2)
```

2.5.5 How to Read and change Parameter Values

Read the values of "mission parameters" by sending the PM command. Do this by typing the characters **?PM** or **?PV** or **?PI** or **?PT** or **?PC** (respectively for mission parameters, Vector parameters, Rudics parameters, Technical parameters and Sensor parameters) in response to ProvBioll 's prompt character ("]") then confirm the command by pressing the Enter key. It should look like this:

?PM

ProvBioll will respond:

```
<PM0 1>
<PM1 0>
<PM2 1>
<PM3 1>
<PM4 4>
<PM5 1000>
<PM6 2000>
<PM7 0>
...
<PM51 2000>
<PM52 1>
]
```

As you can see, the responses are of the form:

- PM parameter number, value.

You can also read the values of the parameters individually using the command

? PM X

where **X** identifies the parameter. Each parameter is identified by a parameter number corresponding to a parameter name. They are summarised for reference in section 5.1

	Abbr.	NAME	DEFAULT VALUE	UNIT	MIN VALUE	MAX VALUE
	PM0	Number of profiles per cycle	1	-	1	10
	PM1	Delay Before Mission	0	Minutes	0	1440
	PM2	Reference Day	1	Mission day	0	364
1st P R O F I L E	PM3	Day for 1 st surfacing	1	Mission day	1	364
	PM4	Estimated hour for 1 st surfacing ⁽¹⁾	4	Hour in the day	0	23
	PM5	Drift Depth	1000	dBars	100	2000
	PM6	Profile Depth	2000	dBars	100	2030
	PM7	Transmission for 1st profile (0 = N, 1 = Y)	0		0	1
2nd	PM8	Day for 2 nd surfacing	1	Mission day	1	364

P R O F I L E	PM9	Estimated hour for 2 nd surfacing ⁽¹⁾	4	Hour in the day	0	23
	PM10	Drift Depth	1000	dBars	100	2000
	PM11	Profile Depth	2000	dBars	100	2030
	PM12	Transmission for 2 nd profile (0 = N, 1 = Y)	0		0	1
3 rd P R O F I L E	PM13	Day for 3 rd surfacing	1	Mission day	1	364
	PM14	Estimated hour for 3 rd surfacing ⁽¹⁾	4	Hour in the day	0	23
	PM15	Drift Depth	1000	dBars	100	2000
	PM16	Profile Depth	2000	dBars	100	2030
	PM17	Transmission for 3 rd profile (0 = N, 1 = Y)	0		0	1
4 th P R O F I L E	PM18	Day for 4 th surfacing	1	Mission day	1	364
	PM19	Estimated hour for 4 th surfacing ⁽¹⁾	4	Hour in the day	0	23
	PM20	Drift Depth	1000	dBars	100	2000
	PM21	Profile Depth	2000	dBars	100	2030
	PM22	Transmission for 4 th profile (0 = N, 1 = Y)	0		0	1
5 th P R O F I L E	PM23	Day for 5 th surfacing	1	Mission day	1	364
	PM24	Estimated hour for 5 th surfacing ⁽¹⁾	4	Hour in the day	0	23
	PM25	Drift Depth	1000	dBars	100	2000
	PM26	Profile Depth	2000	dBars	100	2030
	PM27	Transmission for 5 th profile (0 = N, 1 = Y)	0		0	1
6 th P R O F I L E	PM28	Day for 6 th surfacing	1	Mission day	1	364
	PM29	Estimated hour for 6 th surfacing ⁽¹⁾	4	Hour in the day	0	23
	PM30	Drift Depth	1000	dBars	100	2000
	PM31	Profile Depth	2000	dBars	100	2030
	PM32	Transmission for 6 th profile (0 = N, 1 = Y)	0		0	1
7 th P R O F I L E	PM33	Day for 7 th surfacing	1	Mission day	1	364
	PM34	Estimated hour for 7 th surfacing ⁽¹⁾	4	Hour in the day	0	23
	PM35	Drift Depth	1000	dBars	100	2000
	PM36	Profile Depth	2000	dBars	100	2030
	PM37	Transmission for 7 th profile (0 = N, 1 = Y)	0		0	1
8 th P R O F I L E	PM38	Day for 8 th surfacing	1	Mission day	1	364
	PM39	Estimated hour for 8 th surfacing ⁽¹⁾	4	Hour in the day	0	23
	PM40	Drift Depth	1000	dBars	100	2000
	PM41	Profile Depth	2000	dBars	100	2030
	PM42	Transmission for 8 th profile (0 = N, 1 = Y)	0		0	1
9 th P R O F I L E	PM43	Day for 9 th surfacing	1	Mission day	1	364
	PM44	Estimated hour for 9 th surfacing ⁽¹⁾	4	Hour in the day	0	23
	PM45	Drift Depth	1000	dBars	100	2000
	PM46	Profile Depth	2000	dBars	100	2030

L E 10 th P R O F I L E	PM47	Transmission for 9 th profile (0 = N, 1 = Y)	0		0	1
	PM48	Day for 10 th surfacing	1	Mission day	1	364
	PM49	Estimated hour for 10 th surfacing ⁽¹⁾	4	Hour in the day	0	23
	PM50	Drift Depth	1000	dBars	100	2000
	PM51	Profile Depth	2000	dBars	100	2030
	PM52	Transmission for 10 th profile (0 = N, 1 = Y)	1		0	1

For example, to verify the value of the drift pressure target (1st profile), send the command:

? PM 5

ProvBioll will respond:

```
<PM5 1000>
```

```
]
```

The commands for **changing** the values of the mission parameters are of the form:

!PM X Y

where X identifies the parameter and Y provides its new value.

For example, to change the profile depth to 2030 (max value) for 1st profile, send the command:

```
!PM 06 2030
```

ProvBioll will respond:

```
<PM6 2030>
```

NOTE: *ProvBioll will always respond by confirming the present value of the parameter. This is true even if your attempt to change the parameter's value has been unsuccessful, so you should observe carefully how ProvBioll responds to your commands.*

In a same way, to read vector parameters, user send the command :

?PV

Float will respond with vector parameters list.

Iridium parameters can be read with command :

?PI

Float will respond with udics parameters list.

To read sensor parameters, send the command :

?PC x with x is sensor number identification (see [section 5.3](#) for more details).

Float will respond with Sensor “x” parameters list.

All **command list** is given in [section 6 “USER COMMANDS”](#)

2.5.6 How to Check and change the Time

Connect the PC to the float using the BT connection (see [section 2.5.2](#)). Ask ProvBioll to display the time stored in its internal clock by sending the command:

? TI

(Do this by typing the characters **? TI** followed by the Enter key). ProvBioll will respond:

Get measure ?TI

Command Measure: ?TI

#TI 15:29:11 12/09/12

DATE/TIME Measure: 15:29:11 12/09/12

]]

The date and time are in the format hh:mm:ss DD/MM/YY

You can set the time on the float's internal clock by sending the command:

!TI hh:mm:ss DD/MM/YY

For example, if you send the command:

!TI 14:30:00 01/03/13

ProvBioll will respond:

01/03/13, 14h 30m 00s

2.5.7 Configuration Check

The float has been programmed at the factory. The objective of this portion of the acceptance test is to verify the float's configuration parameters.

Connect the PC to the float (see [section 2.5.2](#)). Send the PM command, as explained in [section 2.5.5](#). to verify that ProvBioll 's parameters have been set correctly.

2.5.8 Functional Tests

Connect the PC to the float (see [section 2.5.2](#)).

NOTE: *The hydraulic components will function correctly only if the float is in a vertical position with the antenna up.*

Orient the float vertically, and support it to prevent it from falling over during the performance of the functional tests.

ProvBioll has several commands that allow you to test its various functions.

2.5.8.1 **Complete AUTO-TEST**

Send the command :

!C0

ProvBioll will respond:

AUTOTEST

Test FLASH

< FLASH: OK (DB7C) >

Test VACUUM

< VACUUM: OK (700) >

Test BAT

< BAT: OK >

Test RES

Remplissage reservoir

<RV ON>

< RES: OK >

Test MEASURE

< MEASURE: OK >

Test MODEM

< MODEM: OK >

****AUTOTEST OK****

]

Sensor will be tested only if sampling period is different from zero (at least in one phase and/or zone).

[Sampling period](#) description can be find in [section 5.3.2](#).

2.5.8.2 **Full auto-test**

A full auto-test, includes Rudics connection to server. Float must be placed outside, with satellite visibility.

Send the command :

!C1

Float answer same information than with **!C0** command but establish a server connection (rudics transmission)

2.5.8.3 *Display of technological parameters*

2 commands are used (?VB and !RV):

Send the command:

?VB

ProvBioll will respond:

Mesure vide interne

<B:107 V:705 (A=1.687 B=-368.240)>

] -> means 705 mBar internal and 10.7V Battery pack voltage

- Internal vacuum (V).

This vacuum is drawn on the float as one of the final steps of assembly. It should be between 600 and 800 mbar absolute. 700 mbar is recommended (with external bladder full @ 20°C).

- Battery voltage (B)

Normal values for a new battery are 10.8 volts (see test sheets for limits).

Send the command :

!RV

Float will respond with:

<RV ON> if lower blade is full.

If lower blade is not full pump will activate until oil has been transferred and lower blade is full. By this way, initial buoyancy will be maximal at deployment.

Before using RV command, float must be in vertical position. If float is in box, test could be false.

2.5.8.4 *Test of CTD sensor (sensor 0)*

This command is used to display:

- External pressure (P).
- Temperature (T).
- Salinity (S).

Send the command:

?ME 0

ProvBioll will respond:

Get mesure ?ME

Command Measure: ?ME 0

]ONE SHOT Measure: 0 CTD -0.0548 24.8029 0.4743

Float Frame Format : ONE SHOT Measure : 0 CTD x y z

With x = Pressure (in cBars)

y = temperature in °C

z = Salinity in PSU

As this sensor is in open air, only the temperature data should be regarded as accurate.

2.5.8.5 *Test of Oxygen sensor (sensor 1)*

This command is used to perform an acquisition on the oxygen sensor.

Send the command :

?ME 1

Float will respond with :

< Get mesure ?ME 1

ONE SHOT Measure: 1 DO 43 586 32.6750 2.6810 26.5220 >

Float Frame Format : ONE SHOT Measure : 1 DO a b c d e

With a = Optode type (43 means Aanderaa 4330)

b = Sensor serial number

c = C1Phase in °

d = C2Phase in °

e = Optode temperature in °C

2.5.8.6 Test of OCR504 sensor (sensor 2)

This command is used to perform an acquisition on the OCR504 sensor.

Send the command :

?ME 2

Float will respond with :

< Get measure ?ME 2

*ONE SHOT Measure: 2 OCR 207 2147647634 2147636480.0000 0.0000 1.1610 2147178340
2147187456.0000 0.0000 1.3680 2147044288 2147054976.0000 0.0000 1.3650 2147389467
2147311232.0000 0.0000 1.3589 >*

Float Frame Format : ONE SHOT Measure : 2 OCR a b c d e f g h i j k l m n

With a = Sensor Serial number

b = Channel (λ_1), sampled A/D counts from the first optical channel

c = A0(λ_1),OPTIC2 fit type a0 coefficient for channel 1

d = A1(λ_1),OPTIC2 fit type a1 coefficient for channel 1

e = Im(λ_1),OPTIC2 fit type Im (immersion) coefficient for channel 1

f = Channel (λ_2), sampled A/D counts from the second optical channel

g = A0(λ_2),OPTIC2 fit type a0 coefficient for channel 2

h = A1 (λ_2),OPTIC2 fit type a1 coefficient for channel 2

i = Im(λ_2),OPTIC2 fit type Im (immersion) coefficient for channel 2

j = Channel (λ_3), sampled A/D counts from the third optical channel

k = A0(λ_3),OPTIC2 fit type a0 coefficient for channel 3

l = A1(λ_3),OPTIC2 fit type a1 coefficient for channel 3

m = Im(λ_3),OPTIC2 fit type Im (immersion) coefficient for channel 3

n = Channel (PAR), sampled A/D counts from the fourth optical channel, PAR

o = A0(λ_3),OPTIC2 fit type a0 coefficient for channel 4

p = A1(λ_3),OPTIC2 fit type a1 coefficient for channel 4

q = Im(λ_3),OPTIC2 fit type Im (immersion) coefficient for channel 4

2.5.8.7 Test of ECOFL Sensor (sensor 3)

This command is used to perform an acquisition on the ECOFL sensor.

Send the command :

?ME 3

Float will respond with :

< Command Measure: ?ME 3

ONE SHOT Measure: 3 ECO3 3906 4130 4130 2317 0.0073 48 0.0000 49 0.0901 43 >

ECO FL frame will be different depending on ECO FL type

ECO FL type can be ECO triplet (ECO3), ECO triplet (ECO3) integrated in "A" or "B Pack" (Satlantics integration), ECO FLBBCD, ECO FLBB2k, ECO FLBB BB

With ECO FL = ECO3 integrated in A or B pack

Float Frame Format : **ONE SHOT Measure: 3 ECO3 a b c d e f g h i j**

With a = Raw Data chl, sampled A/D counts from the chlorophyll fluorometer

b = RawData**bb**, sampled A/D counts from the Scattering fluorometer

c = RawData**CDOM**, sampled A/D counts from the CDOM fluorometer

d = Sensor serial number

e = SFchl, Chlorophyl Scale Factor, the POLYF fit typa A0 coefficient

f = Darkchl, Chlorophyl Dark Offset, the POLYF fit typa A1 coefficient

g = SF**bb**, scattering Scale Factor, the POLYF fit typa A0 coefficient

h = Dark**bb**, scattering Dark Offset, the POLYF fit typa A1 coefficient

i = SF**cdom**, CDOM Scale Factor, the POLYF fit typa A0 coefficient

j = Dark**cdom**, CDOM Dark Offset, the POLYF fit typa A1 coefficient

With ECO FL = Single ECO FL (WETLABS sensor only)

Float Frame Format : **ONE SHOT Measure: 3 ECO a b c d e f g* h* i**

With a = Date (99/99/99)

b = Hour (99:99:99)

c = λ 1 channel

d = λ 1 sig, sampled A/D counts from the λ 1

e = λ 2 Channel

f = λ 2 sig, sampled A/D counts from the λ 2

g = λ 3 Channel

* : not included in ECO FL bb-2k sensor

h = λ 3 sig, Sampled A/D counts from the λ 3

* : not included in ECO FL bb-2k sensor

i = thermistor

ECO FLbb-CD :	λ 1 Channel : chlorophyll (695 nm) λ 2 Channel : Scattering (700 nm) λ 3 Channel : CDOM (460 nm)
ECO FLbb-2k :	λ 1 Channel : chlorophyll (695 nm) λ 2 Channel : Scattering (700 nm) λ 3 Channel : none
ECO FLbb bb	λ 1 Channel : Scattering (470 nm) λ 2 Channel : Scattering (700 nm) λ 3 Channel : Chlorophyll A

2.5.8.8 Test of FLNTU sensor (sensor 4)

This command is used to perform an acquisition on the FLNTU sensor.
Send the command :

?ME 4

Float will respond with :

< Get measure ?ME 4

ONE SHOT Measure: 4 FLNTU 11/19/12 08:09:28 695 54 700 484 539 >

Float Frame Format : **ONE SHOT Measure: 4 FLNTU 11/19/12 08:09:28 w x y z**

With w = λ or Chl Ref (depending on FLNTU firmware)

x = CHL Signal

y = λ or Chl Ref (depending on FLNTU firmware)

z = NTU Signal

2.5.8.9 Test of CROVER sensor (sensor 5)

This command is used to perform an acquisition on the CROVER sensor.
Send the command :

?ME 5

Float will respond with :

< Get measure ?ME 5

ONE SHOT Measure: 5 CROVER 39 12009 5 5 32.148 541>

Float Frame Format : **ONE SHOT Measure: 5 CROVER u v w x y z**

With u = Sensor serial number

v = Ref Raw count value, sampled A/D counts

w = Signal Raw count value, sampled A/D counts

x = Corrected signal raw count value, CSCsig

y = Calculated Beam Attenuation, c, in m⁻¹

z = internal thermistor raw count value, sampled A/D counts

2.5.8.10 Test of SUNA sensor (sensor 6)

This command is used to perform an acquisition on the SUNA sensor.

Send the command :

?ME 6

Float will respond with :

< Get measure ?ME 6

ONE SHOT Measure: 6 SUNA -0.440>

Float Frame Format : ONE SHOT Measure: 6 SUNA x

With x = Nitrate concentration

2.5.8.11 Test Hydraulic Pump

To activate the pump for one second, send the command:

!P 100

Listen for the pump running for one second (unit: centiseconds).

2.5.8.12 Test Hydraulic Valve

To activate the valve for one second, send the command:

!E 100

Listen for the actuation of the valve (unit: centiseconds).

2.5.8.13 Test GPS/Iridium Subsystem

Float must be placed in free area, in order satellite communication (GPS and Iridium) can be performed

To test the Iridium transmitter, send the command :

!SE

The float will reprogram time with GPS, then will send a technical message. Put the magnet back in place to stop the transmission.

This command will cause ProvBioll to transmit several messages. They are technical messages, the format of which is described in [section 7](#).

Use email address you give to provider at Iridium activation request, to check transmission was OK (SBD transmission mode only) or check transmitted file on rudics server (rudics transmission mode). The message content is not meaningful, this is a test of the transmission only.

You have now completed the functional tests. Ensure the magnet is in place on the ON/OFF position (see [Figure 2](#)).

2.5.8.14 Check armed mode

To check if armed mode is ON or OFF, send the command :

?AR

Float will respond :

<AR ON> if armed mode is ON or <AR OFF> if armed mode is OFF.

Armed mode set "ON" means that float is ready for deployment. Armed mode set to OFF means that float enters in "user-dialog mode" each time float is powered ON.

Before deployment, armed mode must absolutely be set to ON !

If armed mode is ON, next time float is powered ON, after a delay of 50 seconds, float begin a new mission and it won't be possible to send command to float anymore. During the 50s delay, user can enter in "dialog mode" by connecting on bluetooth and type on "ENTER" character until float send prompt character ("!").

Armed mode is set in factory on request. This information (AR state) can also be verify by reading FIT file

delivered with float.

You have now completed the functional tests. Ensure the magnet is in place on the ON/OFF position (see 2.4.2 Remove protective plugs and magnet).

Tip : To ensure that float is powered OFF, place magnet on ON/OFF before 5th slow valve activation. In that case, if click stopped before 5th activation, you are sure that magnet in on right position and float power is OFF.

DRAFT 6

3 GENERAL DESCRIPTION OF PROVBIOII FLOAT

3.1 ProvBioll (CTS4 base)

The main developments of ProvBioll compared to the CTS-3.1 float are mainly:

- ✓ Embedded software,
- ✓ Electronics,
- ✓ Mechanical interface with sensors

3.1.1 Electronics

A new CPU board has been developed to take in account the obsolescence of components of the CTS-3.1 PROVOR profiler. A new electronic board has been designed to deal with sensor acquisition and treatment.

3.1.2 Embedded software

The CPU board is equipped with a new embedded software taking in account supplementary inputs and possibilities required by the new electronic design including two boards : one for float managing and the other for sensor.

This new software and electronic architecture is called in nke PROVOR CTS4.

PROVBIO-II is a version of PROVOR CTS4 equipped with combination of sensor (CTD and/or Dissolved oxygen sensor, and/or REM-A assembly (=OCR504, ECOFL sensors) and/or REM-B assembly (=OCR504, ECOFL and CROVER7 sensors), and/or SUNA sensor.

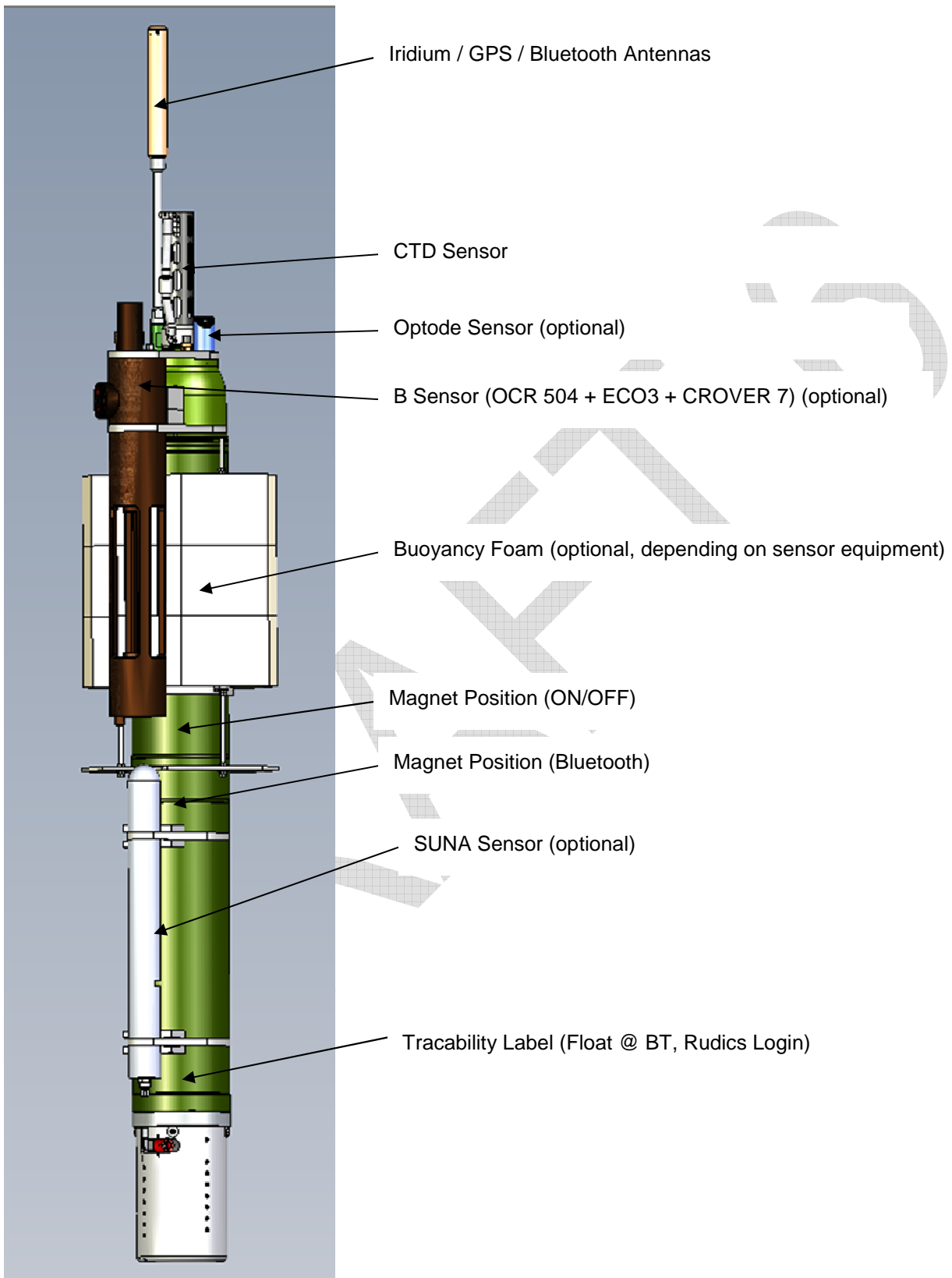

Figure 1 – General view of ProvBioll float

3.2 Density Control System

Descent and ascent depend upon buoyancy. ProvBioll is balanced when its density is equal to that of the level of surrounding water. The float has a fixed mass. A precision hydraulic system is used to adjust its volume. This system inflates or deflates an external bladder by exchanging oil with an internal reservoir. This exchange is performed by a hydraulic system comprising a high-pressure pump and a solenoid valve.

The interested reader is referred to a more detailed description of the operation of ProvBioll 's density control system in [section 9](#).

3.3 Sensors

ProvBioll is equipped with precision instruments for measuring :

- pressure, temperature and salinity with the SEABIRD SBE41CP CTD sensor. Specifications of the sensor are provided in [section 8](#). This sensor is always mounted on float.

Optional sensors :

- Dissolved Oxygen with the Oxygen Optode AANDERAA 3830 or 4330 sensor
- FLNTU Sensor (WETLABS sensor)
- Irradiance, with Satlantic OCR504 sensor
- Transmittance with WETLABS, CROVER-7 sensor
- Chlorophyll, CDOM and backscattering with WETLABS ECO3 sensor
- Nutrients with Satlantic SUNA Sensor

NB : some sensors can be integrated in the same housing. EX : REM-B sensor is an assembly of OCR504, CROVER7 and ECO3 sensor. 2nd Ex : ORCA sensor is an assembly of CROVER7 and ECO-FLBB-2B.

3.4 Iridium Transmitter

While the float is at the surface, the Iridium transmitter sends stored data to the satellites of the Iridium system (see [sections 7. And 7.1.](#)). The transmitter has a unique ID assigned by Iridium (IMEI number). This ID identifies the individual float. The Iridium antenna is mounted on the top end of the ProvBioll float and must be above the sea surface in order for transmissions to reach the satellites.

3.5 CPU Board

This board contains a micro-controller (or CPU) that controls ProvBioll . Its functions include maintenance of the calendar and internal clock, supervision of the depth cycling process and activation and control of the hydraulics.

This board allows communication with the outside world for the purpose of testing and programming.

3.6 Measure Board

This board contains a micro-controller (or CPU) that drive all sensors (power ON & OFF, frame acquisition, storage, treatment and communication with CPU board for transmission phase.

3.7 Battery

A battery of lithium thionyl chloride cells supplies the energy required to operate ProvBioll .

3.8 MMI link

The User link is made via Bluetooth (radiofrequency link)

3.9 Firmware evolutions

With firmware V3.00 (both vector and acquisition board), in 2017, CTS4 has introduced new functions and new strategy fo Rudics transmission. Main new function deals with Ice detection function.

DRAFT 6

4 THE LIFE OF AN PROVBIOLL FLOAT

The life of an ProvBioll float is divided into four phases: Storage/Transport, Deployment, Mission, and Life Expiry.

(1) Storage/Transport

During this phase, the float, packed in its transport case, awaits deployment. The electronic components are dormant, and float's buoyancy control functions are completely shut down. This is the appropriate status for both transport and storage.

(2) Deployment

The float is removed from its protective packaging, configured, tested and launched at sea.

(3) Mission

The mission begins with the launching of the float. During the Mission, ProvBioll conducts a pre-programmed number of cycles of descent, submerged drift, ascent and data transmission. During these cycles it collects measurement data and transmits it to the Iridium satellite system.

(4) Life Expiry

Life Expiry begins automatically upon completion of the pre-programmed number of cycles. During Life Expiry, the float, drifting on the sea surface, periodically transmits messages until the battery is depleted. Reception of these messages makes it possible to locate the float, to follow its movements and, if desired, to recover it. ProvBioll floats are designed to be expendable, so recovery is not part of its normal life cycle. However, float can be ordered to enter in new mission with specific telecommand.

If the battery is depleted before completion of the pre-programmed number of cycles, ProvBioll will probably remain submerged and cannot be located or recovered.

4.1 The Mission - Overview

We call "Mission" the period between the moment when the float is launched at the experiment zone and the moment when the data transmission relating to the final depth cycle is completed.

During the Mission, ProvBioll conducts ascent and descent profiles, separated by periods of Iridium transmitting and drifting at a predetermined depth. ProvBioll can collect data during the descent, submerged drift, or ascent portions of the cycle, and transmits the collected data during the surface drift period at the end of each cycle. One cycle is shown in the figure below.

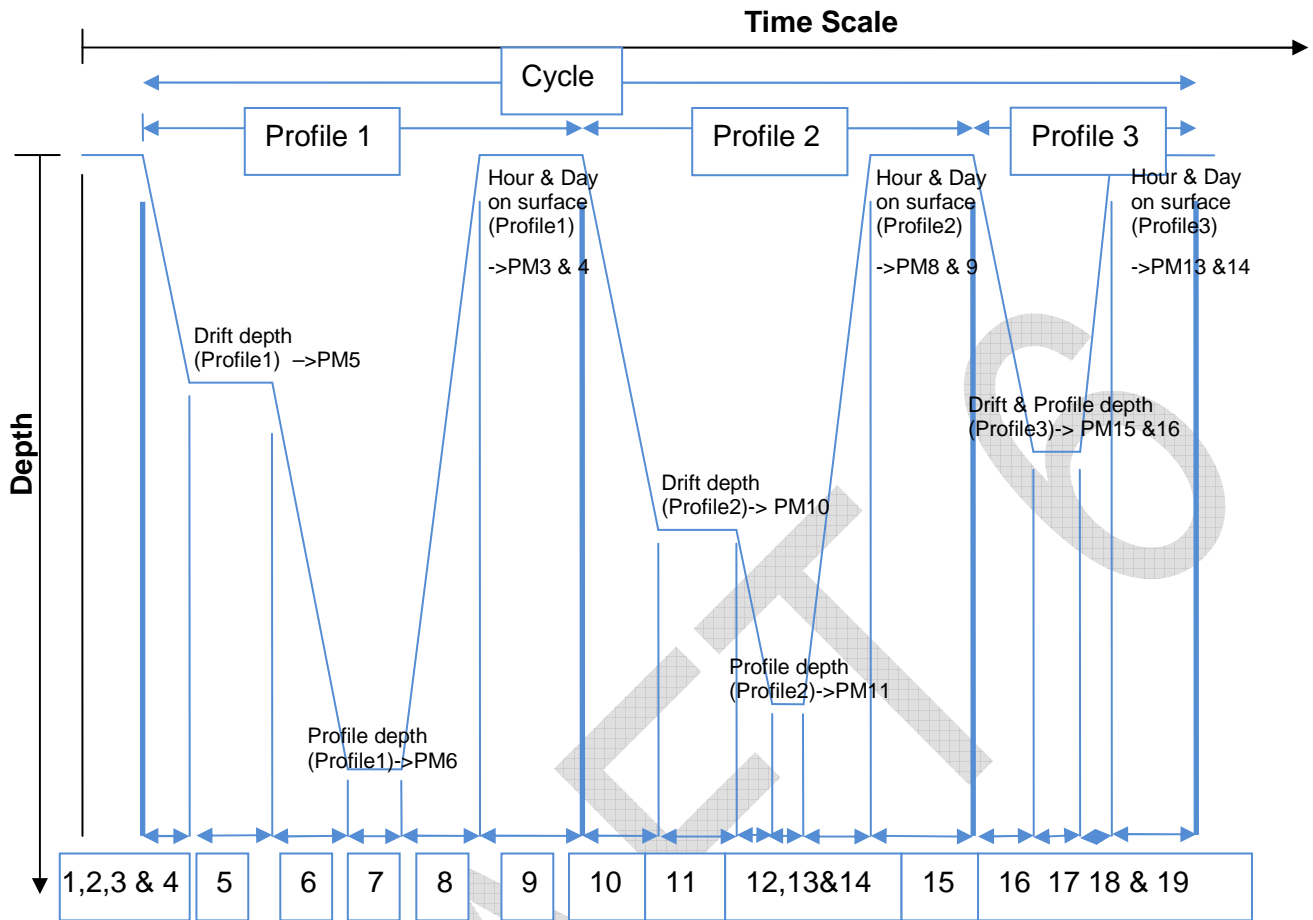

Figure 2 - Schematic representation of a PROVIO-II's cycle (ex with 3 profiles) during the Mission

- (1) **Delay Before Mission**
To prevent ProvBioll from trying to sink before it is in the water, the float waits for this time before starting its descent. This happens only before the first cycle; it is not repeated at each cycle.
- (2) **IRIDIUM Preliminary Transmissions**
To test Iridium transmitter, before descent phase, float will perform Iridium transmission by sending a technical message. A GPS position will be acquired and transmitted in technical message.
- (3) **Buoyancy reduction (1st profile)**
Float is deployed with full external bladder to get a maximal buoyancy. To reach a neutral buoyancy position before descending, float needs to transfer oil inside float. For the 2 first cycles this phase can take up to one hour and a half (by opening electro-valve several times with one minute for pressure monitoring between activations). At following cycles, float memorizes necessary global electro-valve opening time (precedent cycle) and reduce this global duration by reducing time between valve activations to 4 seconds instead of 1 minute.
- (4) **Descent (1st profile)**
The float descends with an average vertical speed of 3 cm/sec. During descent, which typically lasts a few hours, ProvBioll can detect possible grounding on a high portion of the seabed and can move away from such places (see [section 4.3](#). for more details on grounding).
- (5) **Drifting at Depth (1st profile)**
During the drift period, ProvBioll drifts underwater at a user-selected drift depth, typically 1,000m to 2,000m below the sea surface. The drift period duration is user-selectable and can last from a few days to several weeks, but is typically 10 days. The float automatically adjusts its buoyancy if it drifts from the selected depth by more than 5 bars over a 60-minute period. ProvBioll can collect measurements at user-selected intervals during this drift period if the user selects this option.

(6) Descent to Profile Depth (1st profile)

The user may select a starting depth for the ascent profile that is deeper than the drift depth. If this is the case, ProvBioll must first descend to the profile depth before beginning the ascent profile.

ProvBioll can detect a possible grounding during this descent and take corrective action (as described in [section 4.3.](#)).

(7) Wait for Ascent Time (1st profile)

The user can program several floats to conduct profiles simultaneously. This makes it possible to use several ProvBioll floats in a network of synoptic measurements, even though the instruments have not been all deployed at the same time. If this is the case, it may be necessary for ProvBioll to standby at the profile starting depth while awaiting the scheduled ascent time.

(8) Ascent (1st profile)

Ascent lasts a few hours, during which time ProvBioll ascends to the sea surface at an average speed of 9-10cm/sec.

(9) Transmission (1st profile)

At the end of each cycle, the float finds sufficient buoyancy to ensure Iridium transmission quality. ProvBioll remains at the sea surface transmitting the data collected during the preceding drift- ascent portion of the cycle. Except for last profile of cycle, transmission can be requested or not. If transmission is not requested for 1st profiles of cycle, user must program a transmission for last profile, in order to transmit all data acquired during all profiles. According to [PM7](#) on 1st profile.

(10) Buoyancy reduction + Descent (2nd profile)**(11) Drifting at Depth (2nd profile)****(12) Descent to Profile Depth (2nd profile)****(13) Wait for Ascent Time (2nd profile)****(14) Ascent (2nd profile)****(15) Transmission (2nd profile).** According to [PM12](#) on 2nd profile.**(16) Buoyancy reduction + Descent (3rd profile)****(17) Drifting at parking + drifting at Depth (3rd profile)**

This profile is programmed with same Parking and Profile Depth

(18) Ascent (3rd profile)**(19) Transmission (3rd profile)**

According to [PM17](#) on 3rd profile. Last transmission for cycle. If previous profiles were programmed without transmission, all data will be transmitted at this time. Transmission for last profile MUST be set to "1" by user

4.2 Descent

While the float is still at the sea surface ProvBioll measures and records its pressure sensor offset. This offset is used to correct all pressure measurements. The offset is transmitted in a technical message (see [section 7](#)) for a description of the technical message format). Descent takes the float from the sea surface to the drift depth. Initially, in order to avoid possible collisions with ships, ProvBioll 's objective is to lose buoyancy in the shortest possible time. It does this by opening the solenoid valve for a time period that is initially long, but decreases as the float approaches its target depth.

4.3 Grounding

ProvBioll monitors itself for possible grounding on the seabed. During descent to drift depth, if the pressure remains unchanged for too long, ProvBioll enters a correction mode. The user selects one of two available modes during Mission programming before launch (technical parameter PT13) :

- Grounding Mode = 0 (PT13=0) : The pre-programmed drift depth is disregarded. The pressure at the time of grounding minus an offset (5 bar) is taken as the new value for the drift pressure. The float adjusts its buoyancy to reach this new drift depth. The drift depth reverts to its programmed value for subsequent cycles. If the grounded pressure is lower than a programmed threshold (20 bar), the float remains on the seabed until the next programmed ascent time.

- Grounding Mode = 1 (PT13=1) : the float remains where it is until the next scheduled ascent time. The pressure measured at grounding becomes the profile start pressure for the cycle in progress. The profile start pressure reverts to its programmed value for subsequent cycles.

4.4 Submerged Drift

While ProvBioll is drifting at drift depth, it checks the external pressure regularly to determine whether there is need either for depth adjustment or for an emergency ascent.

If the measured pressure differs from the drift depth pressure by more than a specified tolerance, and this difference is maintained, ProvBioll adjusts its buoyancy to return to the drift depth.

If the pressure increases by an amount that exceeds a factory-set danger threshold (technical parameter), ProvBioll immediately ascends to the sea surface.

If the user chooses, ProvBioll will collect measurements at user-selected intervals during submerged drift.

4.5 Ascent

If the chosen ascent profile starting pressure is higher than the drift pressure, the float must first descend to reach the profile starting pressure.

If grounding is detected while ProvBioll is descending to the profile starting pressure, the present pressure is substituted for the profile starting pressure. This substitution is only for the cycle in progress; the profile starting pressure reverts to its pre-programmed value for subsequent cycles.

Once the profile starting pressure has been reached, the float waits for the programmed time to begin the ascent. If this time is reached before the float has arrived at the profile starting pressure, the ascent starts immediately.

ProvBioll ascends by repeated use of the pump. When the pressure change between two successive measurements is less than 1 bar, the pump is activated for a pre-set time period. In this way, the pump performs minimum work at high pressure, which ensures minimum electrical energy consumption. The average speed of ascent is approximately 9-10cm/sec. For a 2,000m profile, the ascent would therefore last 6 hours.

When the pressure drops below 1 bar (signifying completion of ascent), ProvBioll waits 10 minutes and then activates the pump in order to empty the reservoir and achieve maximum buoyancy. Sensor measurements begin at the profile start time and stop 10 minutes after the float rises above the 1 bar isobar in its approach to the sea surface.

4.5.1 Ice detection (with firmware V3.00 and higher)

At the end of ascent, if Ice detection option is activated, float will start ice detection in order to stop ascent and avoid hit ice with risk to remain blocked under ice.

To detect Ice, float uses 3 mechanisms :

- ISA method (Ice Sensing Algorithm)
- Satellite visibility
- Pressure evolution

If ice is detected, float stop ascent and abort satellite transmission. In that case, Iridium packets are created and stored into float internal memory for transmission next time float will really reach surface.

4.5.1.1 ISA detection

Between 2 threshold,; float computes median temperature. If temperature is inferior to -1.79°C, float decide Ice detection as positive. From threshold PG3, float decreases speed from approx. 9 cm/sec to approx. 3.33 cm/sec (default values), to acquire necessary raw CTD data to compute median temperature

4.5.1.2 Satellite visibility

A 2nd mechanism enables to detect ice, based on GPS end Iridium satellite visibility.

4.5.1.3 Pressure evolution

A 3rd mechanism is based on pressure evolution during ascent phase. If, despite pump actions, pressure evolution is inferior to minimum value, float decides Ice detection as positive.

Once Ice detection is positive, float activates valve to transfer oil (volume given by PT25 parameter). In the same time, float creates Iridium packet for past cycle, and stored all packet in non-volatile memory. These packets will be transmit during next transmission session. More ancient packet will be erased by new ones, in case, float remain for long time under water without emergence & transmission

4.6 Multi-Profiles

ProvBioll float can realize up to 10 profiles per cycle. All profiles are independently parametered.

For each profile, user can set, day and hour on surface, parking and profile depth, sensor slices and area for acquisition and treatment (raw, average, ...). Transmission for each profile can also be programmed or not.

For example, in case a cycle is parametered for realizing 10 profiles, each of 9 nine first profiles can be transmitted or not at the end of each profile. Transmission will be forced by the float at the end of the last profile. In case no transmission were programmed during the nine first profiles, final transmission will send messages for the complete cycle.

4.7 Transmission

The data transmission process takes into account the limitations of the Iridium data collection system, including :

- the uncertainty of the float's antenna emerging in rough seas;
- radio propagation uncertainties due to weather conditions, and;
- the satellites' operational status.

ProvBioll creates transmission messages from the stored data.

Please refer to [section 7](#). for a detailed description of the transmitted message formats.

5 PROVBIOII PARAMETERS

ProvBioll can be controlled and parametered with 5 set of parameters :

- [Mission parameters](#)
- [Vector parameters](#)
- [Sensor parameters](#)
- [Ice parameters](#)
- [Iridium Parameters](#) (Rudics transmission used only, not used with SBD transmission)
- **Technical parameters (not described in this manual. For specific request contact nke-instrumentation)**

ProvBioll 's configuration is determined by the values of its mission parameters defined below. Instructions on how to read and change the values of these parameters are provided in [sections 2.5.5](#).

5.1 Mission Parameters

The following table summarizes all mission parameter names, ranges and default values.

Mission parameters are used to describe all profile in the cycle. For each profile, user has to set :Day and hour for surfacing, drift and Profile depth, and set if transmission is requested at end of the profile. All data acquired during profile with no transmission will be transmitted during 1st transmission.

	Abbr.	NAME	DEFAULT VALUE	UNIT	MIN VALUE	MAX VALUE
	PM0	Number of profiles per cycle	1	-	1	10
	PM1	Delay Before Mission	0	Minutes	0	1440
	PM2	Reference Day (day for 1 st surfacing during 1 st cycle after deployment)	1	Mission day	0	364
1 st P R O F I L E	PM3	Day for 1 st surfacing	1	Mission day	1	364
	PM4	Estimated hour for 1 st surfacing ⁽¹⁾	4	Hour in the day	0	23
	PM5	Drift Depth	1000	dBars	100	2000
	PM6	Profile Depth	2000	dBars	100	2030
	PM7	Transmission for 1st profile (0 = N, 1 = Y)	0		0	1
2 nd P R O F I L E	PM8	Day for 2 nd surfacing	1	Mission day	1	364
	PM9	Estimated hour for 2 nd surfacing ⁽¹⁾	4	Hour in the day	0	23
	PM10	Drift Depth	1000	dBars	100	2000
	PM11	Profile Depth	2000	dBars	100	2030
	PM12	Transmission for 2 nd profile (0 = N, 1 = Y)	0		0	1
3 rd P R O F I L E	PM13	Day for 3 rd surfacing	1	Mission day	1	364
	PM14	Estimated hour for 3 rd surfacing ⁽¹⁾	4	Hour in the day	0	23
	PM15	Drift Depth	1000	dBars	100	2000
	PM16	Profile Depth	2000	dBars	100	2030
	PM17	Transmission for 3 rd profile (0 = N, 1 = Y)	0		0	1

4 th P R O F I L E	PM18	Day for 4 th surfacing	1	Mission day	1	364
	PM19	Estimated hour for 4 th surfacing ⁽¹⁾	4	Hour in the day	0	23
	PM20	Drift Depth	1000	dBars	100	2000
	PM21	Profile Depth	2000	dBars	100	2030
	PM22	Transmission for 4 th profile (0 = N, 1 = Y)	0		0	1
5 th P R O F I L E	PM23	Day for 5 th surfacing	1	Mission day	1	364
	PM24	Estimated hour for 5 th surfacing ⁽¹⁾	4	Hour in the day	0	23
	PM55	Drift Depth	1000	dBars	100	2000
	PM26	Profile Depth	2000	dBars	100	2030
	PM27	Transmission for 5 th profile (0 = N, 1 = Y)	0		0	1
6 th P R O F I L E	PM28	Day for 6 th surfacing	1	Mission day	1	364
	PM29	Estimated hour for 6 th surfacing ⁽¹⁾	4	Hour in the day	0	23
	PM30	Drift Depth	1000	dBars	100	2000
	PM31	Profile Depth	2000	dBars	100	2030
	PM32	Transmission for 6 th profile (0 = N, 1 = Y)	0		0	1
7 th P R O F I L E	PM33	Day for 7 th surfacing	1	Mission day	1	364
	PM34	Estimated hour for 7 th surfacing ⁽¹⁾	4	Hour in the day	0	23
	PM35	Drift Depth	1000	dBars	100	2000
	PM36	Profile Depth	2000	dBars	100	2030
	PM37	Transmission for 7 th profile (0 = N, 1 = Y)	0		0	1
8 th P R O F I L E	PM38	Day for 8 th surfacing	1	Mission day	1	364
	PM39	Estimated hour for 8 th surfacing ⁽¹⁾	4	Hour in the day	0	23
	PM40	Drift Depth	1000	dBars	100	2000
	PM41	Profile Depth	2000	dBars	100	2030
	PM42	Transmission for 8 th profile (0 = N, 1 = Y)	0		0	1
9 th P R O F I L E	PM43	Day for 9 th surfacing	1	Mission day	1	364
	PM44	Estimated hour for 9 th surfacing ⁽¹⁾	4	Hour in the day	0	23
	PM45	Drift Depth	1000	dBars	100	2000
	PM46	Profile Depth	2000	dBars	100	2030
	PM47	Transmission for 9 th profile (0 = N, 1 = Y)	0		0	1
10 th P R O F I L E	PM48	Day for 10 th surfacing	1	Mission day	1	364
	PM49	Estimated hour for 10 th surfacing ⁽¹⁾	4	Hour in the day	0	23
	PM50	Drift Depth	1000	dBars	100	2000
	PM51	Profile Depth	2000	dBars	100	2030
	PM52	Transmission for 10 th profile (0 = N, 1 = Y)	1		0	1

Table 1 - Summary of ProvBioll user-programmable Mission Parameters

5.1.1 Mission Parameters details (PM)

PM(0) Number of Different Profiles per Cycle

This is the number of profiles of descent, submerged drift, ascent and transmission that ProvBioll will perform during one cycle. The mission ends and ProvBioll enters Life Expiry mode when this number of cycles has been completed.

The capacity of ProvBioll 's batteries is sufficient for at least 180 cycles (1 profile). If you wish to recover ProvBioll at the end of the mission, you must set the number of cycles at less than 180 to ensure there is sufficient battery capacity remaining to allow ProvBioll to return to the sea surface and enter Life Expiry.

Under favourable conditions, the battery capacity may exceed 180 cycles (possible more than 300 cycles depending on sensor equipment and sampling strategy). If you do not plan to recover the ProvBioll float, you may choose to set the number of cycles to 180 to ensure that ProvBioll completes the maximum number of cycles possible.

PM(1) Delay Before Mission (minutes)

To prevent ProvBioll from trying to sink while still on launch boat's, the float waits for this time before commanding the buoyancy engine to start the descent. After disconnection of the PC, followed by removal of the magnet, ProvBioll will wait for this delay before beginning the descent. The delay is measured after the first start of the pump which confirms the removal of the magnet (see [section 2.4.1](#)) and before the start of the descent.

PM(2) Reference Day (day number)

Allows you to configure a group of floats so that they all conduct their profiles at the same time. The parameter defines a particular day on which the first profile is to be made. When the float's internal clock's day number equals the reference day, it will conduct its first profile. The float's internal clock day number is set to zero when the mission starts. When setting the reference day, it is recommended to allow enough time between the deployment and reach of profiling depth. Using a reference day of at least 2 will ensure the first profile is complete.

PM3 to PM 7 for 1st profile

PM(3) Day for 1st surfacing

Relative day for 1st profile (float arrives on surface).

PM(4) Estimated Hour on Surface (hours)

Estimated time float must reach surface (associate to PM3 (or PM2 during first cycle after deployment) day).

PM(5) Drift Depth (dbar)

The depth at which ProvBioll drifts after completion of a descent while awaiting the time scheduled for the beginning of the next ascent.

PM(6) Profile Depth (dbar)

Depth at which profiling begins ascending profile. If ProvBioll is drifting at some shallower depth, it will first descend to the profile depth before starting the ascent profile.

PM(7) Transmission

Set if Iridium transmission is requested (0 = no, 1 = yes). Transmission will be forced by the float for last profile of the cycle.

PM8 to PM12 for 2nd profile

Identical PM3 to PM7 respectively for 2nd profile

PM13 to PM17 for 3rd profile

Identical PM3 to PM7 respectively for 3rd profile

PM18 to PM22 for 4th profile
Identical PM3 to PM7 respectively for 4th profile

PM23 to PM27 for 5th profile
Identical PM3 to PM7 respectively for 5th profile

PM28 to PM32 for 6th profile
Identical PM3 to PM7 respectively for 6th profile

PM33 to PM37 for 7th profile
Identical PM3 to PM7 respectively for 7th profile

PM38 to PM42 for 8th profile
Identical PM3 to PM7 respectively for 8th profile

PM43 to PM47 for 9th profile
Identical PM3 to PM7 respectively for 9th profile

PM48 to PM52 for 10th profile
Identical PM3 to PM7 respectively for 10th profile

DRAFT 6

5.2 Vector parameters (PV)

This set of parameters is used for programming in advance date for changing “Cycle period”.

5 different “cycle period” can be programmed in advance.

These parameters must be used with great precautions, because mission parameters have also to be changed, because all surfacing days could be false with new cycle period.

NB : Use of pre-programmed cycle period is recommended only for mono-cycle profile, because in that case, day and hour on surface (mission parameters) have to adjusted for all profiles if more than one profile is set. Nke recommend not to use more than 1 pre-programmed cycle period for cycles with multi-profiles.

Abbr.	NAME	DEFAULT VALUE	UNIT	MIN VALUE	MAX VALUE
PV0	Number of different cycle duration	1		1	5
PV1	Iridium End-Of-Life Period	60	Minutes	10	7200
PV2	Iridium 2 nd session waiting time (“0” means no 2 nd session)	10	Minutes	0	360
PV3	Cycle Period1	24	Hours	24	4320
PV4	End Day for “Cycle Period” 1	31	Day	31	31
PV5	End Month for “Cycle Period” 1	12	Month	12	12
PV6	End Year for “Cycle Period” 1	99	Year	99	99
PV7	Cycle Period2	24	Hours	24	4320
PV8	End Day for “Cycle Period 2”	31	Day	31	31
PV9	End Month for “Cycle Period” 2	12	Month	12	12
PV10	End Year for “Cycle Period” 2	99	Year	99	99
PV11	Cycle Period3	24	Hours	24	4320
PV12	End Day for “Cycle Period 3	31	Day	31	31
PV13	End Month for “Cycle Period” 3	12	Month	12	12
PV14	Année de fin pour durée 3	99	Year	99	99
PV15	Cycle Period4	24	Hours	24	4320
PV16	End Day for “Cycle Period 4	31	Day	31	31
PV17	End Month for “Cycle Period” 4	12	Month	12	12
PV18	End Year for “Cycle Period” 4	99	Year	99	99
PV19	Cycle Period5	24	Hours	24	4320
PV20	End Day for “Cycle Period 5	31	Day	31	31
PV21	End Month for “Cycle Period” 5	12	Month	12	12
PV22	End Year for “Cycle Period” 5	99	Year	99	99

With firmware V3.00 and higher

Abbr.	NAME	DEFAULT VALUE	UNIT	MIN VALUE	MAX VALUE
PV0	Number of different cycle duration	1		1	1
PV1	Iridium End-Of-Life Period	60	Minutes	10	7200
PV2	Iridium 2 nd session waiting time ("0" means no 2 nd session)	10	Minutes	0	360
PV3	Cycle Period1	24	Hours	24	4320
PV4	End Day for "Cycle Period" 1	31	Day	31	31
PV5	End Month for "Cycle Period" 1	12	Month	12	12
PV6	End Year for "Cycle Period" 1	99	Year	99	99

DRAFT

5.2.1 Vector Parameters details

PV(0) Number of different cycles Duration

This parameter enables to anticipate cycle period modification. In case you want float realizes for example 5-days cycles up to a specific date, then 7 days-cycles, you can specify, 2 different duration. Float cycle period will be 5 days (PV3 = 5) up to date specify by PV4, 5 & 6. Once this date is reached, float will entered in 2nd period, considering PV7 as the new cycle period. Up the date specified with PV8, 9 & 10. Using several Cycle period is not recommended for multi-profiles cycles, because, changing Cycle period request also to modify Mission parameters for each profile. (Unchangeable with firmware V3.00 and higher)

PV(1) Iridium End of life period (minutes)

Transmission period (in minutes) once float is in "end of life mode" (all programmed cycles have been reached. Float send Technical message with refreshed GPS point.

PV(2) Iridium Inter-cycles wait period (min)

If this parameter is not null, a second iridium session (assigned to the next cycle number) will occur PV2 minutes after the last transmission session of the current cycle. This enables to check if a change on mission or technical parameter has been correctly treated by the float and if new parameters are effective for next cycle.

PV(3) Cycle duration for period 1

Indicate cycle duration for all the cycles that were programmed (i.e. until the date defined by PV4, PV5 and PV6

PV(4) End of "period 1" day

PV(5) End of "period 1" month

PV(6) End of "period 1" year

Once PV 4, 5 and 6 are reached, float will change cycle period to PV7 (Cycle duration for period 2) if at least 2 period are set (see PV 0), or float will enter in End-Of life mode if only one period was set

Using more than 1 cycle period is not recommended in case of cycle with muti-profiles, because a cycle period change request also to modify hour and day for profile surfacing (PM parameters) and these parameters cannot be changed in advance (only with iridium telecommand), meaning risk of bad programmation increase highly.

5.3 Sensor parameters (PC)

Each sensor has 2 sets of parameters :

Standard parameters and **Specific parameters**

Standard parameters deal with sampling period in each of the 5 zones in all phase (descent, drift, ascent,), slice thickness, threshold, treatment type and Power Supply Mode.

Specific parameters are used for setting different parameters linked exclusively to one sensor (Warm-Up time, calibration coefficients, ...).

Standard parameters structures are identical for all sensors. **Specific parameters** structures are different from one sensor to another.

5.3.1 How to read and modify Sensor Parameter

To read sensor parameter, send the command :

?PC x with x Sensor number, according to the following table

Float will answer with all sensor parameter (standard and specific)

To modify Sensor parameter, send the command :

!PC w x y z, where **w** means Sensor number, **x** to indicate if this is standard (=0) or specific (=1) parameter, **Y** means parameter number, and **Z** value for parameter

Prior to sensor parameter modification, user have to unlock access, with command :

!KC 1234

Float will answer

Set measure !KC

LOCK UNLOCK Measure: READ/WRITE ACCESS

Same command is used for lock again parameters access

See [section 6](#) for details about User commands syntax and explanations

Sensor	Sensor number
CTD	0
Optode	1
OCR504	2
ECO3	3
FLNTU	4
cROVER7	5
SUNA	6

5.3.2 Standard parameter information

Sampling Period : Deal with period for each sensor acquisition of raw data (5 parameters per zone : 1 in any phase of float : descent to parking depth, drift at parking depth, descent to profile depth, drift at profile depth, ascent profile). If all sampling period (in each of the 5 zone) are set to "zero", sensor is considered as "not mounted on Float", meaning it is not tested during auto-test.

NB : A sensor not mounted (i.e. with all sampling period set to zero) at float deployment **MUST NOT BE ACTIVATED** then by Iridium telecommand during float's mission. If user wants one sensor physically mounted on float and not active at the beginning of mission, he should set all "power acquisition mode" to zero. By this way, sensor will not be acquired until telecommand reception. If all sampling period are set to zero before deployment, memory organization is created without considering this sensor, so activate sensor during mission with telecommand will cause a failure in data memorization. That's why, for specific mission with sensor not active at beginning, user have to set sampling period different from zero (so sensor will be tested during auto-test and memory organization will take in account), and uses "power acquisition mode" to activate or deactivate sampling

Power Acquisition Mode : You can choose, no acquisition (=0), pulsed mode (=2) or Continuous (=3).

Pulsed Mode means Sensor is Powered On for acquisition, then Supply is OFF until next sample (depending on requested sampling period). This mode enable to save energy. Using pulsed mode need precautions regarding sampling period.

Sampling period must be > ("[Sensor Power Warm-up Time](#)" + "[Power OFF time between Power ON retry](#)" + 2 seconds). If sampling period is too short regarding sensor specific parameters, mode will be forced in continuous mode. Specific parameters details are given in [section 5.3.3](#)

Continuous mode means sensor is continuously powered ON during ascent or descent profile.

No acquisition means, sensor won't be acquired

Treatment Type : Float acquires samples for each sensors, then these samples (called Raw data) are computed in accordance with zone (zone 1 for surface zone to zone 5 for the deepest zone) and slice thickness. Treatment consist in averaging (=3) (decimation then averaging) or in Averaging + additional information (Standard deviation and Median, in that case =7). If Standard deviation and Median are set, additional packets will be transmitted (Cf 7.2.4 describing packets formats).

Slices thickness : Used for raw data computation. In one slice, all raw data are computed to generate one treated data that will be transmitted in Iridium message.

Threshold between zone : Used to determine pressure target for slice thickness modification.

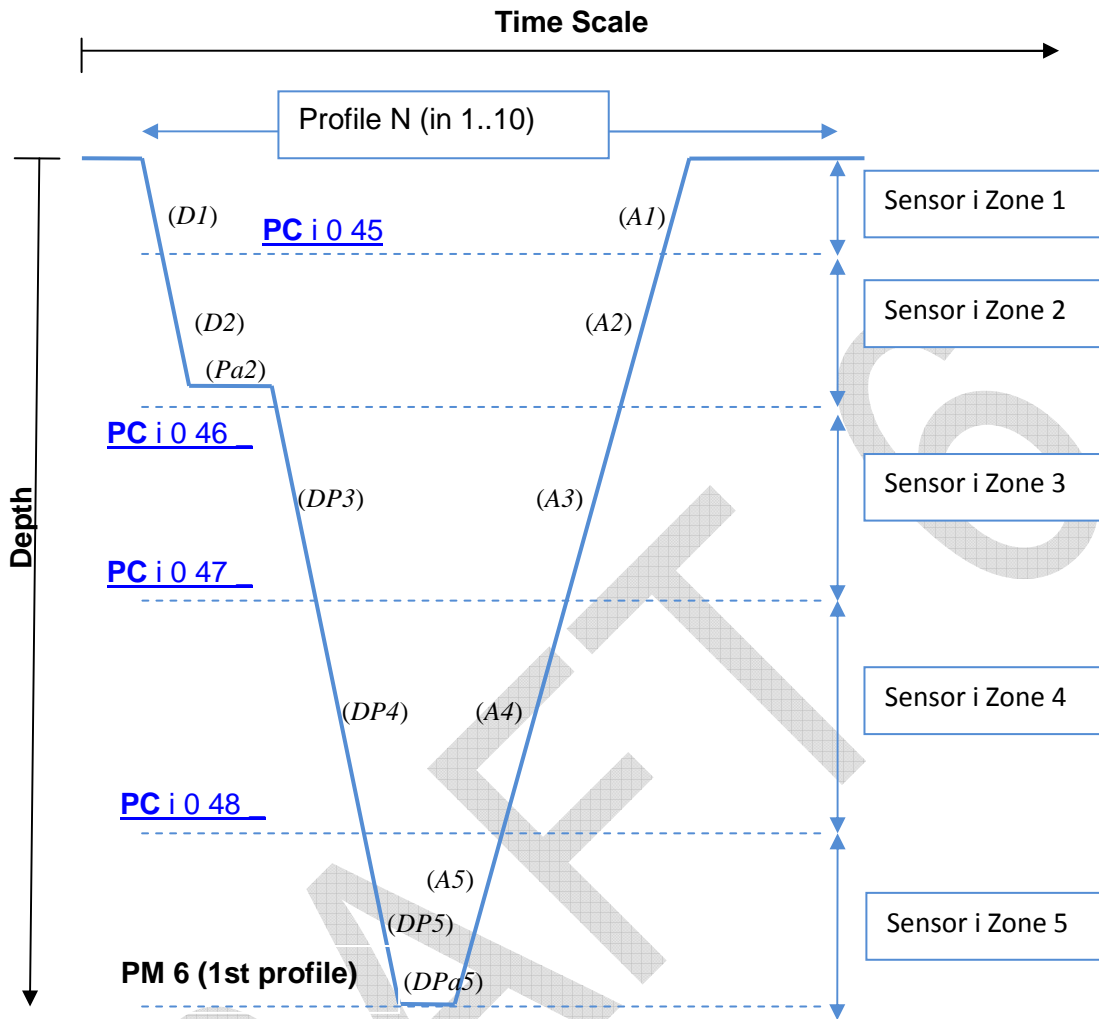

Figure 3 - Sensor zone description

For each sensor, profile is divided in 5 zone (separated with 4 thresholds between 5 zones) as described on figure 3.

Within each zone, could be defined :

- Acquisition mode (Off, Pulsed or Continuous)
- Data processing (raw, mean or mean + median + standard deviation) for transmission
- slice thickness (depth resolution) within which data will be processed.
- Sampling rate during float descent (D), Parking Drift (Pa), descent to starting profile depth (DP), deep parking (DPa) and ascent to surface (A).

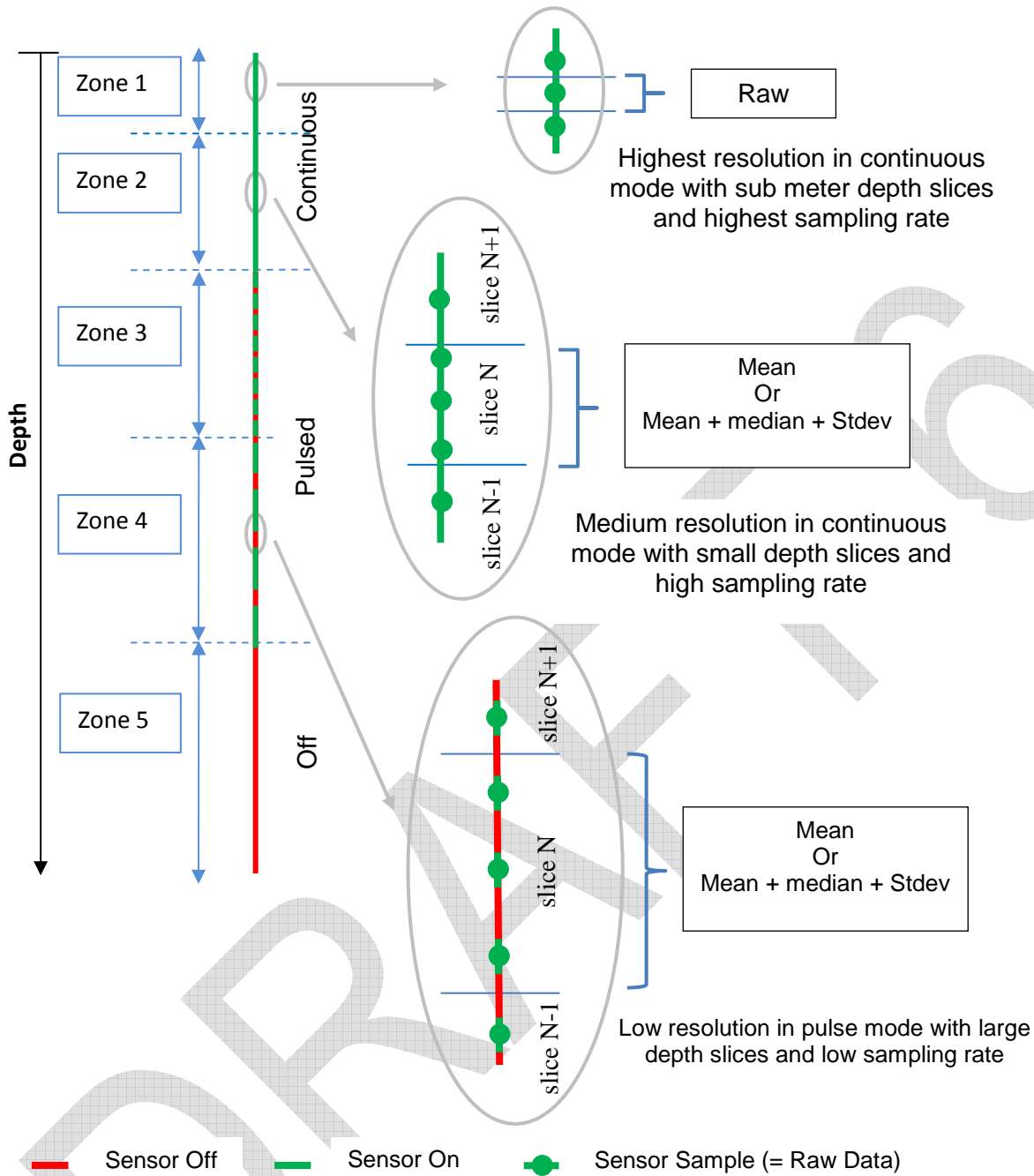

Figure 4 – Power Supply Mode description

Sensor powering and data acquisition options along a profile. The ProvBioll float allows balancing power consumption and data resolution by controlling the sensor power supply, the sampling rate and the thickness of slices within which data will be processed. These parameters could be defined independently for each sensor for five depth intervals (Zones).

5.3.3 Specific parameter information

All specific parameters have been set in factory. Modification on specific parameters can cause trouble in sensor acquisition. Before specific modifications, contact **nke instrumentation**.

The 4 first specific parameters are identical for all sensor. Then following parameters are completely specific to each sensor.

- 1- **Sensor Power Warm-up Time** : This parameter indicates timing before sensor deliver 1st sample after sensor is powered ON.
- 2- **Power OFF time between Power ON retry** : this parameter indicates timing for sensor power to remain OFF before sensor is powered ON again, in order sensor power supply applies a good reset to sensor.
- 3- **1st «valid sample» rank** : This parameter indicates which sample can be considered as valid. Count begins from "0", meaning first sample (raw data) coming from sensor is considered as valid.
- 4- **Number of raw data per slice in ECO mode** : not implemented for the moment.

In the specific parameters of a given sensor we usually can find :

Min value : Indicate for each measure, minimal value that will be acquired. Rejected if inferior

Max value : Indicate for each measure, maximal value that will be acquired. Rejected if superior

5.3.4 CTD parameters (Sensor "0")

5.3.4.1 CTD Standard parameters

STANDARD SENSOR PARAMETERS (TYPE 0) – SENSOR 0 (CTD)						
Abbr.	NAME	DEFAULT VALUE	UNIT	MIN VALUE	MAX VALUE	REQUEST VALUE
PC 0 0 0	Sampling period in descent to parking depth (zone 1)	0	sec	0	3600	
PC 0 0 1	Sampling period in Parking Drift (zone 1)	60	min	0	3600	
PC 0 0 2	Sampling period in Descent To Profile Depth (zone 1)	0	sec	0	3600	
PC 0 0 3	Sampling period in Profile Depth Drift (zone 1)	0	min	0	3600	
PC 0 0 4	Sampling period in Ascent Profile (zone 1)	10	sec	0	3600	
PC 0 0 5	Power Acquisition Mode in zone 1 (0 : none, 2 : pulsed, 3 : continuous)	3		0	3	
PC 0 0 6	Treatment Type in zone 1 (0 : raw, 1 : average, 7 : Average/Median/Standard Deviation)	1		0	7	
PC 0 0 7	NOT USED	0		0	0	
PC 0 0 8	Slices Thickness for zone 1	1	dBars	1	500	
PC 0 0 9	Sampling period in descent to parking depth (zone 2)	0	sec	0	3600	
PC 0 0 10	Sampling period in Parking Drift (zone 2)	60	min	0	3600	
PC 0 0 11	Sampling period in Descent To Profile Depth (zone 2)	0	sec	0	3600	
PC 0 0 12	Sampling period in Profile Depth Drift (zone 2)	0	min	0	3600	
PC 0 0 13	Sampling period in Ascent Profile (zone 2)	10	sec	0	3600	
PC 0 0 14	Power Acquisition Mode in zone 2 (0 : none, 2 : pulsed, 3 : continuous)	3		0	3	
PC 0 0 15	Treatment Type in zone 2 (0 : raw, 1 : average, 7 : Average/Median/Standard Deviation)	1		0	7	
PC 0 0 16	NOT USED	0		0	0	
PC 0 0 17	Slices Thickness for zone 2	5	dBars	1	500	

PC 0 0 18	Sampling period in descent to parking depth (zone 3)	0	sec	0	3600
PC 0 0 19	Sampling period in Parking Drift (zone 3)	60	min	0	3600
PC 0 0 20	Sampling period in Descent To Profile Depth (zone 3)	0	sec	0	3600
PC 0 0 21	Sampling period in Profile Depth Drift (zone 3)	0	min	0	3600
PC 0 0 22	Sampling period in Ascent Profile (zone 3)	10	sec	0	3600
PC 0 0 23	Power Acquisition Mode in zone 3 (0 : none, 2 : pulsed, 3 : continuous)	3		0	3
PC 0 0 24	Treatment Type in zone 3 (0 : raw, 1 : average, 7 : Average/Median/Standard Deviation)	1		0	7
PC 0 0 25	NOT USED	0		0	0
PC 0 0 26	Slices Thickness for zone 3	10	dBars	1	500
PC 0 0 27	Sampling period in descent to parking depth (zone 4)	0	sec	0	3600
PC 0 0 28	Sampling period in Parking Drift (zone 4)	60	min	0	3600
PC 0 0 29	Sampling period in Descent To Profile Depth (zone 4)	0	sec	0	3600
PC 0 0 30	Sampling period in Profile Depth Drift (zone 4)	0	min	0	3600
PC 0 0 31	Sampling period in Ascent Profile (zone 4)	10	sec	0	3600
PC 0 0 32	Power Acquisition Mode in zone 4 (0 : none, 2 : pulsed, 3 : continuous)	3		0	3
PC 0 0 33	Treatment Type in zone 4 (0 : raw, 1 : average, 7 : Average/Median/Standard Deviation)	1		0	7
PC 0 0 34	NOT USED	0		0	0
PC 0 0 35	Slices Thickness for zone 4	20	dBars	1	500
PC 0 0 36	Sampling period in descent to parking depth (zone 5)	0	sec	0	3600
PC 0 0 37	Sampling period in Parking Drift (zone 5)	60	min	0	3600
PC 0 0 38	Sampling period in Descent To Profile Depth (zone 5)	0	sec	0	3600
PC 0 0 39	Sampling period in Profile Depth Drift (zone 5)	0	min	0	3600
PC 0 0 40	Sampling period in Ascent Profile (zone 5)	10	sec	0	3600
PC 0 0 41	Power Acquisition Mode in zone 5 (0 : none, 2 : pulsed, 3 : continuous)	3		3	3
PC 0 0 42	Treatment Type in zone 5 (0 : raw, 1 : average, 7 : Average/Median/Standard Deviation)	1			7
PC 0 0 43	NOT USED	0			0
PC 0 0 44	Slices Thickness for zone 5	25	dBars	1	500
PC 0 0 45	Threshold zone 1 / zone 2	10	dBars	1	2200
PC 0 0 46	Threshold zone 2 / zone 3	200	dBars	1	2200
PC 0 0 47	Threshold zone 3 / zone 4	500	dBars	1	2200
PC 0 0 48	Threshold zone 4 / zone 5	1000	dBars	1	2200

See [section 5.3.2](#) for standard parameters details.

5.3.4.2 CTD Specific parameters

SPECIFIC SENSOR PARAMETERS (TYPE 1) – SENSOR 0 (CTD)					
Abbr.	NAME	DEFAULT VALUE	UNIT	MIN VALUE	MAX VALUE
PC 0 1 0	Sensor Power Warm-up Time	4800	msec	0	65535
PC 0 1 1	Power OFF time between Power ON retry	5000	msec	0	65535
PC 0 1 2	1st «valid sample» rank	0		0	255
PC 0 1 3	Number of raw data per slice in ECO mode	1		1	255
PC 0 1 4	<u>Cut-off Pressure</u>	5	dBars	0	65535
PC 0 1 5	Min Pressure	-5	dBars	Mini float	Maxi float
PC 0 1 6	Max Pressure	2500	dBars	Mini float	Maxi float
PC 0 1 7	Min temperature	-5	m°C	Mini float	Maxi float
PC 0 1 8	Max temperature	50	m°C	Mini float	Maxi float
PC 0 1 9	Min salinity	0	mPSU	Mini float	Maxi float
PC 0 1 10	Max salinity	50	mPSU	Mini float	Maxi float
PC 0 1 11	Min ascent speed	0.083	m/s	0.01	0.5
PC 0 1 12	Min descent speed	0.01	m/s	0.01	0.5
PC 0 1 13	Extrude acquisition during hydraulic pump activation	0		0	1
PC 0 1 14	ISA Mode	0		0	2
PC 0 1 15	ISA Start pressure	50	dBars		
PC 0 1 16	SA Stop pressure	20	dBars		
PC 0 1 17	Median temperature	-1790	m°C		
PC 0 1 18	Median salinity		mPSU		

Cut-Off Pressure : indicate SBE 41 Cut-off Pressure. As float reach this pressure, in ascent profile, CTD pump is stopped, but CTD sample acquisition continues. In case this pressure is included inside a theoretical slice, an additional treatment is made by float, in order in 1 slice, samples acquired with and without pump are not averaged.

Example : 2 dBars slice on surface, with Cut-Off Pressure to 5 dBars. Cut-Off Pressure is included inside slice [4;6] dBars.

In that case, float will force a treatment with raw data included in range [6;5] dBars (with sample acquired as pump is active), and then realize another treatment with raw data included in range [5;4] dBars (raw data acquired as pump is not active).

By this way, a treated data cannot include raw data acquired with and without pumping.

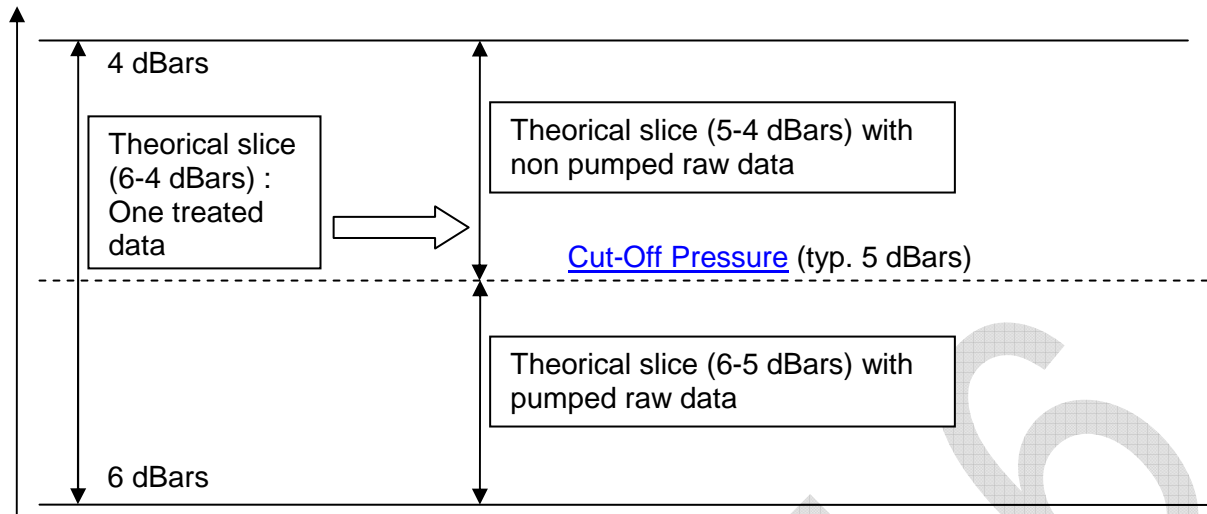

DRAFT 6

See [section 5.3.3](#) for specific parameters details.

5.3.5 Optode Parameters (Sensor “1”)

5.3.5.1 Optode Standard parameters

STANDARD SENSOR PARAMETERS (TYPE 0) – SENSOR 1 (OPTODE)						
Abbr.	NAME	DEFAULT VALUE	UNIT	MIN VALUE	MAX VALUE	REQUEST VALUE
PC 1 0 0	Sampling period in descent to parking depth (zone 1)	0	sec	0	3600	
PC 1 0 1	Sampling period in Parking Drift (zone 1)	0	min	0	3600	
PC 1 0 2	Sampling period in Descent To Profile Depth (zone 1)	0	sec	0	3600	
PC 1 0 3	Sampling period in Profile Depth Drift (zone 1)	0	min	0	3600	
PC 1 0 4	Sampling period in Ascent Profile (zone 1)	0	sec	0	3600	
PC 1 0 5	Power Acquisition Mode in zone 1 (0 : none, 2 : pulsed, 3 : continuous)	3		0	3	
PC 1 0 6	Treatment Type in zone 1 (0 : raw, 1 : average, 7 : Average/Median/Standard Deviation)	1		0	7	
PC 1 0 7	NOT USED	1		1	1	
PC 1 0 8	Slices Thickness for zone 1	1	dBars	1	500	
PC 1 0 9	Sampling period in descent to parking depth (zone 2)	0	sec	0	3600	
PC 1 0 10	Sampling period in Parking Drift (zone 2)	0	min	0	3600	
PC 1 0 11	Sampling period in Descent To Profile Depth (zone 2)	0	sec	0	3600	
PC 1 0 12	Sampling period in Profile Depth Drift (zone 2)	0	min	0	3600	
PC 1 0 13	Sampling period in Ascent Profile (zone 2)	0	sec	0	3600	
PC 1 0 14	Power Acquisition Mode in zone 2 (0 : none, 2 : pulsed, 3 : continuous)	3		0	3	
PC 1 0 15	Treatment Type in zone 2 (0 : raw, 1 : average, 7 : Average/Median/Standard Deviation)	1		0	7	
PC 1 0 16	NOT USED	1		1	1	
PC 1 0 17	Slices Thickness for zone 2	5	dBars	1	500	
PC 1 0 18	Sampling period in descent to parking depth (zone 3)	0	sec	0	3600	
PC 1 0 19	Sampling period in Parking Drift (zone 3)	0	min	0	3600	
PC 1 0 20	Sampling period in Descent To Profile Depth (zone 3)	0	sec	0	3600	
PC 1 0 21	Sampling period in Profile Depth Drift (zone 3)	0	min	0	3600	
PC 1 0 22	Sampling period in Ascent Profile (zone 3)	0	sec	0	3600	
PC 1 0 23	Power Acquisition Mode in zone 3 (0 : none, 2 : pulsed, 3 : continuous)	3		0	3	
PC 1 0 24	Treatment Type in zone 3 (0 : raw, 1 : average, 7 : Average/Median/Standard Deviation)	1		0	7	
PC 1 0 25	NOT USED	1		1	1	
PC 1 0 26	Slices Thickness for zone 3	10	dBars	1	500	
PC 1 0 27	Sampling period in descent to parking depth (zone 4)	0	sec	0	3600	
PC 1 0 28	Sampling period in Parking Drift (zone 4)	0	min	0	3600	
PC 1 0 29	Sampling period in Descent To Profile Depth (zone 4)	0	sec	0	3600	
PC 1 0 30	Sampling period in Profile Depth Drift (zone 4)	0	min	0	3600	
PC 1 0 31	Sampling period in Ascent Profile (zone 4)	0	sec	0	3600	

PC 1 0 32	Power Acquisition Mode in zone 4 (0 : none, 2 : pulsed, 3 : continuous)	3		0	3	
PC 1 0 33	Treatment Type in zone 4 (0 : raw, 1 : average, 7 : Average/Median/Standard Deviation)	1		0	7	
PC 1 0 34	NOT USED	1		1	1	
PC 1 0 35	Slices Thickness for zone 4	20	dBars	1	500	
PC 1 0 36	Sampling period in descent to parking depth (zone 5)	0	sec	0	3600	
PC 1 0 37	Sampling period in Parking Drift (zone 5)	0	min	0	3600	
PC 1 0 38	Sampling period in Descent To Profile Depth (zone 5)	0	sec	0	3600	
PC 1 0 39	Sampling period in Profile Depth Drift (zone 5)	0	min	0	3600	
PC 1 0 40	Sampling period in Ascent Profile (zone 5)	0	sec	0	3600	
PC 1 0 41	Power Acquisition Mode in zone 5 (0 : none, 2 : pulsed, 3 : continuous)	3		3	3	
PC 1 0 42	Treatment Type in zone 5 (0 : raw, 1 : average, 7 : Average/Median/Standard Deviation)	1		0	7	
PC 1 0 43	NOT USED	1		1	1	
PC 1 0 44	Slices Thickness for zone 5	25	dBars	1	500	
PC 1 0 45	Threshold zone 1 / zone 2	10	dBars	1	2200	
PC 1 0 46	Threshold zone 2 / zone 3	200	dBars	1	2200	
PC 1 0 47	Threshold zone 3 / zone 4	500	dBars	1	2200	
PC 1 0 48	Threshold zone 4 / zone 5	1000	dBars	1	2200	

See [section 5.3.2](#) for standard parameters details.

5.3.5.2 Optode Specific parameters

SPECIFIC SENSOR PARAMETERS (TYPE 1) – SENSOR 1 (OPTODE)						
Abbr.	NAME	DEFAULT VALUE	UNIT	MIN VALUE	MAX VALUE	REQUEST VALUE
PC 1 1 0	Sensor Power Warm-up Time	1500	msec	0	65535	
PC 1 1 1	Power OFF time between Power ON retry	10000	msec	0	65535	
PC 1 1 2	1st «valid sample» rank	0		0	255	
PC 1 1 3	Number of raw data per slice in ECO mode	1		1	255	
PC 1 1 4	Min C1 phase	Mini float	deg	Mini float	Maxi float	
PC 1 1 5	Max C1 phase	Maxi float	deg	Mini float	Maxi float	
PC 1 1 6	Min C2 phase	Mini float	deg	Mini float	Maxi float	
PC 1 1 7	Max C2 phase	Maxi float	deg	Mini float	Maxi float	
PC 1 1 8	Min T°	Mini float	m°C	Mini float	Maxi float	
PC 1 1 9	Max T°	Maxi float	m°C	Mini float	Maxi float	
PC 1 1 10	Extrude acquisition during hydraulic pump activation	0		0	1	

See [section 5.3.3](#) for specific parameters details.

5.3.6 OCR504 Parameters (Sensor “2”)

5.3.6.1 OCR504 Standard parameters

STANDARD SENSOR PARAMETERS (TYPE 0) – SENSOR 2 (OCR504)						
Abbr.	NAME	DEF VALUE	UNIT	MIN VALUE	MAX VALUE	REQ VALUE
PC 2 0 0	Sampling period in descent to parking depth (zone 1)	0	sec	0	3600	
PC 2 0 1	Sampling period in Parking Drift (zone 1)	0	min	0	3600	
PC 2 0 2	Sampling period in Descent To Profile Depth (zone 1)	0	sec	0	3600	
PC 2 0 3	Sampling period in Profile Depth Drift (zone 1)	0	min	0	3600	
PC 2 0 4	Sampling period in Ascent Profile (zone 1)	0	sec	0	3600	
PC 2 0 5	Power Acquisition Mode in zone 1 (0 : none, 2 : pulsed, 3 : continuous)	3		0	3	
PC 2 0 6	Treatment Type in zone 1 (0 : raw, 1 : average, 7 : Average/Median/Standard Deviation)	1		0	7	
PC 2 0 7	NOT USED	1		1	1	
PC 2 0 8	Slices Thickness for zone 1	1	dBars	1	500	
PC 2 0 9	Sampling period in descent to parking depth (zone 2)	0	sec	0	3600	
PC 2 0 10	Sampling period in Parking Drift (zone 2)	0	min	0	3600	
PC 2 0 11	Sampling period in Descent To Profile Depth (zone 2)	0	sec	0	3600	
PC 2 0 12	Sampling period in Profile Depth Drift (zone 2)	0	min	0	3600	
PC 2 0 13	Sampling period in Ascent Profile (zone 2)	0	sec	0	3600	
PC 2 0 14	Power Acquisition Mode in zone 2 (0 : none, 2 : pulsed, 3 : continuous)	3		0	3	
PC 2 0 15	Treatment Type in zone 2 (0 : raw, 1 : average, 7 : Average/Median/Standard Deviation)	1		0	7	
PC 2 0 16	NOT USED	1		1	1	
PC 2 0 17	Slices Thickness for zone 2	5	dBars	1	500	
PC 2 0 18	Sampling period in descent to parking depth (zone 3)	0	sec	0	3600	
PC 2 0 19	Sampling period in Parking Drift (zone 3)	0	min	0	3600	
PC 2 0 20	Sampling period in Descent To Profile Depth (zone 3)	0	sec	0	3600	
PC 2 0 21	Sampling period in Profile Depth Drift (zone 3)	0	min	0	3600	
PC 2 0 22	Sampling period in Ascent Profile (zone 3)	0	sec	0	3600	
PC 2 0 23	Power Acquisition Mode in zone 3 (0 : none, 2 : pulsed, 3 : continuous)	3		0	3	
PC 2 0 24	Treatment Type in zone 3 (0 : raw, 1 : average, 7 : Average/Median/Standard Deviation)	1		0	7	
PC 2 0 25	NOT USED	1		1	1	
PC 2 0 26	Slices Thickness for zone 3	10	dBars	1	500	
PC 2 0 27	Sampling period in descent to parking depth (zone 4)	0	sec	0	3600	
PC 2 0 28	Sampling period in Parking Drift (zone 4)	0	min	0	3600	
PC 2 0 29	Sampling period in Descent To Profile Depth (zone 4)	0	sec	0	3600	
PC 2 0 30	Sampling period in Profile Depth Drift (zone 4)	0	min	0	3600	
PC 2 0 31	Sampling period in Ascent Profile (zone 4)	0	sec	0	3600	
PC 2 0 32	Power Acquisition Mode in zone 4 (0 : none, 2 : pulsed, 3 : continuous)	3		0	3	
PC 2 0 33	Treatment Type in zone 4 (0 : raw, 1 : average, 7 : Average/Median/Standard Deviation)	1		0	7	

PC 2 0 34	NOT USED	1		1	1	
PC 2 0 35	Slices Thickness for zone 4	20	dBars	1	500	
PC 2 0 36	Sampling period in descent to parking depth (zone 5)	0	sec	0	3600	
PC 2 0 37	Sampling period in Parking Drift (zone 5)	0	min	0	3600	
PC 2 0 38	Sampling period in Descent To Profile Depth (zone 5)	0	sec	0	3600	
PC 2 0 39	Sampling period in Profile Depth Drift (zone 5)	0	min	0	3600	
PC 2 0 40	Sampling period in Ascent Profile (zone 5)	0	sec	0	3600	
PC 2 0 41	Power Acquisition Mode in zone 5 (0 : none, 2 : pulsed, 3 : continuous)	3		3	3	
PC 2 0 42	Treatment Type in zone 5 (0 : raw, 1 : average, 7 : Average/Median/Standard Deviation)	1		0	7	
PC 2 0 43	Synchronization zone 5 (0 : None, 1 : CTD pressure) (NOT USED)	1		1	1	
PC 2 0 44	Slices Thickness for zone 5	25	dBars	1	500	
PC 2 0 45	Threshold zone 1 / zone 2	10	dBars	1	2200	
PC 2 0 46	Threshold zone 2 / zone 3	200	dBars	1	2200	
PC 2 0 47	Threshold zone 3 / zone 4	500	dBars	1	2200	
PC 2 0 48	Threshold zone 4 / zone 5	1000	dBars	1	2200	

See [section 5.3.2](#) for standard parameters details.

5.3.6.2 OCR504 Specific parameters

SPECIFIC SENSOR PARAMETERS (TYPE 1) – SENSOR 2 (OCR504)						
Abbr.	NAME	DEF VALUE	UNIT	MIN VALUE	MAX VALUE	REQ. VALUE
PC 2 1 0	Sensor Power Warm-up Time	1900	msec	0	65535	
PC 2 1 1	Power OFF time between Power ON retry	4000	msec	0	65535	
PC 2 1 2	1st «valid sample» rank	0		0	255	
PC 2 1 3	Number of raw data per slice in ECO mode	1		1	255	
PC 2 1 4	min Irradiance 1	Mini float		Mini float	Maxi float	
PC 2 1 5	max Irradiance 1	Maxi float		Mini float	Maxi float	
PC 2 1 6	min Irradiance 2	Mini float		Mini float	Maxi float	
PC 2 1 7	max Irradiance 2	Maxi float		Mini float	Maxi float	
PC 2 1 8	min Irradiance 3	Mini float		Mini float	Maxi float	
PC 2 1 9	max Irradiance 3	Maxi float		Mini float	Maxi float	
PC 2 1 10	min Irradiance 4	Mini float		Mini float	Maxi float	
PC 2 1 11	max Irradiance 4	Maxi float		Mini float	Maxi float	
PC 2 1 12	Extrude acquisition during hydraulic pump activation	0		0	1	

See [section 5.3.3](#) for specific parameters details.

5.3.7 ECOFL Parameters (Sensor “3”)

5.3.7.1 ECOFL Standard parameters

STANDARD SENSOR PARAMETERS (TYPE 0) – SENSOR 3 (ECOFL)						
Abbr.	NAME	DEF VALUE	UNIT	MIN VALUE	MAX VALUE	REQ VALUE
PC 3 0 0	Sampling period in descent to parking depth (zone 1)	0	sec	0	3600	
PC 3 0 1	Sampling period in Parking Drift (zone 1)	0	min	0	3600	
PC 3 0 2	Sampling period in Descent To Profile Depth (zone 1)	0	sec	0	3600	
PC 3 0 3	Sampling period in Profile Depth Drift (zone 1)	0	min	0	3600	
PC 3 0 4	Sampling period in Ascent Profile (zone 1)	0	sec	0	3600	
PC 3 0 5	Power Acquisition Mode in zone 1 (0 : none, 2 : pulsed, 3 : continuous)	3		0	3	
PC 3 0 6	Treatment Type in zone 1 (0 : raw, 1 : average, 7 : Average/Median/Standard Deviation)	1		0	7	
PC 3 0 7	NOT USED	1		1	1	
PC 3 0 8	Slices Thickness for zone 1	1	dBars	1	500	
PC 3 0 9	Sampling period in descent to parking depth (zone 2)	0	sec	0	3600	
PC 3 0 10	Sampling period in Parking Drift (zone 2)	0	min	0	3600	
PC 3 0 11	Sampling period in Descent To Profile Depth (zone 2)	0	sec	0	3600	
PC 3 0 12	Sampling period in Profile Depth Drift (zone 2)	0	min	0	3600	
PC 3 0 13	Sampling period in Ascent Profile (zone 2)	0	sec	0	3600	
PC 3 0 14	Power Acquisition Mode in zone 2 (0 : none, 2 : pulsed, 3 : continuous)	3		0	3	
PC 3 0 15	Treatment Type in zone 2 (0 : raw, 1 : average, 7 : Average/Median/Standard Deviation)	1		0	7	
PC 3 0 16	NOT USED	1		1	1	
PC 3 0 17	Slices Thickness for zone 2	5	dBars	1	500	
PC 3 0 18	Sampling period in descent to parking depth (zone 3)	0	sec	0	3600	
PC 3 0 19	Sampling period in Parking Drift (zone 3)	0	min	0	3600	
PC 3 0 20	Sampling period in Descent To Profile Depth (zone 3)	0	sec	0	3600	
PC 3 0 21	Sampling period in Profile Depth Drift (zone 3)	0	min	0	3600	
PC 3 0 22	Sampling period in Ascent Profile (zone 3)	0	sec	0	3600	
PC 3 0 23	Power Acquisition Mode in zone 3 (0 : none, 2 : pulsed, 3 : continuous)	3		0	3	
PC 3 0 24	Treatment Type in zone 3 (0 : raw, 1 : average, 7 : Average/Median/Standard Deviation)	1		0	7	
PC 3 0 25	NOT USED	1		1	1	
PC 3 0 26	Slices Thickness for zone 3	10	dBars	1	500	
PC 3 0 27	Sampling period in descent to parking depth (zone 4)	0	sec	0	3600	
PC 3 0 28	Sampling period in Parking Drift (zone 4)	0	min	0	3600	
PC 3 0 29	Sampling period in Descent To Profile Depth (zone 4)	0	sec	0	3600	
PC 3 0 30	Sampling period in Profile Depth Drift (zone 4)	0	min	0	3600	
PC 3 0 31	Sampling period in Ascent Profile (zone 4)	0	sec	0	3600	
PC 3 0 32	Power Acquisition Mode in zone 4 (0 : none, 2 : pulsed, 3 : continuous)	3		0	3	
PC 3 0 33	Treatment Type in zone 4 (0 : raw, 1 : average, 7 : Average/Median/Standard Deviation)	1		0	7	

PC 3 0 34	NOT USED	1		1	1	
PC 3 0 35	Slices Thickness for zone 4	20	dBars	1	500	
PC 3 0 36	Sampling period in descent to parking depth (zone 5)	0	sec	0	3600	
PC 3 0 37	Sampling period in Parking Drift (zone 5)	0	min	0	3600	
PC 3 0 38	Sampling period in Descent To Profile Depth (zone 5)	0	sec	0	3600	
PC 3 0 39	Sampling period in Profile Depth Drift (zone 5)	0	min	0	3600	
PC 3 0 40	Sampling period in Ascent Profile (zone 5)	0	sec	0	3600	
PC 3 0 41	Power Acquisition Mode in zone 5 (0 : none, 2 : pulsed, 3 : continuous)	3		3	3	
PC 3 0 42	Treatment Type in zone 5 (0 : raw, 1 : average, 7 : Average/Median/Standard Deviation)	1		0	7	
PC 3 0 43	NOT USED	1		1	1	
PC 3 0 44	Slices Thickness for zone 5	25	dBars	1	500	
PC 3 0 45	Threshold zone 1 / zone 2	10	dBars	1	2200	
PC 3 0 46	Threshold zone 2 / zone 3	200	dBars	1	2200	
PC 3 0 47	Threshold zone 3 / zone 4	500	dBars	1	2200	
PC 3 0 48	Threshold zone 4 / zone 5	1000	dBars	1	2200	

See [section 5.3.2](#) for standard parameters details.

5.3.7.2 ECO-FL Specific parameters

SPECIFIC SENSOR PARAMETERS (TYPE 1) – SENSOR 3 (ECOFL)						
Abbr.	NAME	DEFAULT VALUE	UNIT	MIN VALUE	MAX VALUE	REQUEST VALUE
PC 3 1 0	Sensor Power Warm-up Time	3600	msec	0	65535	
PC 3 1 1	Power OFF time between Power ON retry	4000	msec	0	65535	
PC 3 1 2	1st «valid sample» rank	0		0	255	
PC 3 1 3	Number of raw data per slice in ECO mode	1		1	255	
PC 3 1 4	Min λ1 Channel (Scattering for ECO3) (counts)	0		Mini float	Maxi float	
PC 3 1 5	Max λ1 Channel (Scattering for ECO3) (counts)	4130		Mini float	Maxi float	
PC 3 1 6	Min λ2 Channel (CDOM for ECO3) (counts)	0		Mini float	Maxi float	
PC 3 1 7	Max λ2 Channel (CDOM for ECO3) (counts)	4130		Mini float	Maxi float	
PC 3 1 8	Min λ3 Channel (Chlorophyll for ECO3) (counts)	0		Mini float	Maxi float	
PC 3 1 9	Max λ3 Channel (Chlorophyll for ECO3) (counts)	4130		Mini float	Maxi float	
PC 3 1 10	Extrude acquisition during hydraulic pump activation	0		0	1	

See [section 5.3.3](#) for specific parameters details.

5.3.8 FLNTU Parameters (Sensor “4”)

5.3.8.1 *FLNTU Standard parameters*

STANDARD SENSOR PARAMETERS (TYPE 0) – SENSOR 4 (FLNTU)						
Abbr.	NAME	DEFAULT VALUE	UNIT	MIN VALUE	MAX VALUE	REQUEST VALUE
PC 4 0 0	Sampling period in descent to parking depth (zone 1)	0	sec	0	3600	
PC 4 0 1	Sampling period in Parking Drift (zone 1)	0	min	0	3600	
PC 4 0 2	Sampling period in Descent To Profile Depth (zone 1)	0	sec	0	3600	
PC 4 0 3	Sampling period in Profile Depth Drift (zone 1)	0	min	0	3600	
PC 4 0 4	Sampling period in Ascent Profile (zone 1)	0	sec	0	3600	
PC 4 0 5	Power Acquisition Mode in zone 1 (0 : none, 2 : pulsed, 3 : continuous)	3		0	3	
PC 4 0 6	Treatment Type in zone 1 (0 : raw, 1 : average, 7 : Average/Median/Standard Deviation)	1		0	7	
PC 4 0 7	NOT USED	1		1	1	
PC 4 0 8	Slices Thickness for zone 1	1	dBars	1	500	
PC 4 0 9	Sampling period in descent to parking depth (zone 2)	0	sec	0	3600	
PC 4 0 10	Sampling period in Parking Drift (zone 2)	0	min	0	3600	
PC 4 0 11	Sampling period in Descent To Profile Depth (zone 2)	0	sec	0	3600	
PC 4 0 12	Sampling period in Profile Depth Drift (zone 2)	0	min	0	3600	
PC 4 0 13	Sampling period in Ascent Profile (zone 2)	0	sec	0	3600	
PC 4 0 14	Power Acquisition Mode in zone 2 (0 : none, 2 : pulsed, 3 : continuous)	3		0	3	
PC 4 0 15	Treatment Type in zone 2 (0 : raw, 1 : average, 7 : Average/Median/Standard Deviation)	1		0	7	
PC 4 0 16	NOT USED	1		1	1	
PC 4 0 17	Slices Thickness for zone 2	5	dBars	1	500	
PC 4 0 18	Sampling period in descent to parking depth (zone 3)	0	sec	0	3600	
PC 4 0 19	Sampling period in Parking Drift (zone 3)	0	min	0	3600	
PC 4 0 20	Sampling period in Descent To Profile Depth (zone 3)	0	sec	0	3600	
PC 4 0 21	Sampling period in Profile Depth Drift (zone 3)	0	min	0	3600	
PC 4 0 22	Sampling period in Ascent Profile (zone 3)	0	sec	0	3600	
PC 4 0 23	Power Acquisition Mode in zone 3 (0 : none, 2 : pulsed, 3 : continuous)	3		0	3	
PC 4 0 24	Treatment Type in zone 3 (0 : raw, 1 : average, 7 : Average/Median/Standard Deviation)	1		0	7	
PC 4 0 25	NOT USED	1		1	1	
PC 4 0 26	Slices Thickness for zone 3	10	dBars	1	500	
PC 4 0 27	Sampling period in descent to parking depth (zone 4)	0	sec	0	3600	
PC 4 0 28	Sampling period in Parking Drift (zone 4)	0	min	0	3600	
PC 4 0 29	Sampling period in Descent To Profile Depth (zone 4)	0	sec	0	3600	
PC 4 0 30	Sampling period in Profile Depth Drift (zone 4)	0	min	0	3600	
PC 4 0 31	Sampling period in Ascent Profile (zone 4)	0	sec	0	3600	
PC 4 0 32	Power Acquisition Mode in zone 4 (0 : none, 2 : pulsed, 3 : continuous)	3		0	3	

PC 4 0 33	Treatment Type in zone 4 (0 : raw, 1 : average, 7 : Average/Median/Standard Deviation)	1		0	7	
PC 4 0 34	NOT USED	1		1	1	
PC 4 0 35	Slices Thickness for zone 4	20	dBars	1	500	
PC 4 0 36	Sampling period in descent to parking depth (zone 5)	0	sec	0	3600	
PC 4 0 37	Sampling period in Parking Drift (zone 5)	0	min	0	3600	
PC 4 0 38	Sampling period in Descent To Profile Depth (zone 5)	0	sec	0	3600	
PC 4 0 39	Sampling period in Profile Depth Drift (zone 5)	0	min	0	3600	
PC 4 0 40	Sampling period in Ascent Profile (zone 5)	0	sec	0	3600	
PC 4 0 41	Power Acquisition Mode in zone 5 (0 : none, 2 : pulsed, 3 : continuous)	3		3	3	
PC 4 0 42	Treatment Type in zone 5 (0 : raw, 1 : average, 7 : Average/Median/Standard Deviation)	1		0	7	
PC 4 0 43	NOT USED	1		1	1	
PC 4 0 44	Slices Thickness for zone 5	25	dBars	1	500	
PC 4 0 45	Threshold zone 1 / zone 2	10	dBars	1	2200	
PC 4 0 46	Threshold zone 2 / zone 3	200	dBars	1	2200	
PC 4 0 47	Threshold zone 3 / zone 4	500	dBars	1	2200	
PC 4 0 48	Threshold zone 4 / zone 5	1000	dBars	1	2200	

See [section 5.3.2](#) for standard parameters details.

5.3.8.2 FLNTU Specific parameters

SPECIFIC SENSOR PARAMETERS (TYPE 1) – SENSOR 4 (FLNTU)					
Abbr.	NAME	DEFAULT VALUE	UNIT	MIN VALUE	MAX VALUE
PC 4 1 0	Sensor Power Warm-up Time	4100	msec	0	65535
PC 4 1 1	Power OFF time between Power ON retry	6000	msec	0	65535
PC 4 1 2	1st «valid sample» rank	0		0	255
PC 4 1 3		1		Mini float	Maxi float
PC 4 1 4	Min Chlorophyll	0		Mini float	Maxi float
PC 4 1 5	Max Chlorophyll	4130		Mini float	Maxi float
PC 4 1 6	Min Turbidity	0		Mini float	Maxi float
PC 4 1 7	Max Turbidity	4130		Mini float	Maxi float
PC 4 1 8	ScaleFactor Chlorophyll				
PC 4 1 9	DarkCounts Chlorophyll	1		Mini float	Maxi float
PC 4 1 10	ScaleFactor Turbidity	0		Mini float	Maxi float
PC 4 1 11	DarkCounts Turbidity	1		Mini float	Maxi float
PC 4 1 12	Extrude acquisition during hydraulic pump activation	0		0	1

See [section 5.3.3](#) for specific parameters details.

5.3.9 CROVER Parameters (Sensor “5”)

5.3.9.1 CROVER Standard parameters

STANDARD SENSOR PARAMETERS (TYPE 0) – SENSOR 5 (cROVER)						
Abbr.	NAME	DEFAULT VALUE	UNIT	MIN VALUE	MAX VALUE	REQUEST VALUE
PC 5 0 0	Sampling period in descent to parking depth (zone 1)	0	sec	0	3600	
PC 5 0 1	Sampling period in Parking Drift (zone 1)	0	min	0	3600	
PC 5 0 2	Sampling period in Descent To Profile Depth (zone 1)	0	sec	0	3600	
PC 5 0 3	Sampling period in Profile Depth Drift (zone 1)	0	min	0	3600	
PC 5 0 4	Sampling period in Ascent Profile (zone 1)	0	sec	0	3600	
PC 5 0 5	Power Acquisition Mode in zone 1 (0 : none, 2 : pulsed, 3 : continuous)	3		0	3	
PC 5 0 6	Treatment Type in zone 1 (0 : raw, 1 : average, 7 : Average/Median/Standard Deviation)	1		0	7	
PC 5 0 7	NOT USED	1		1	1	
PC 5 0 8	Slices Thickness for zone 1	1	dBars	1	500	
PC 5 0 9	Sampling period in descent to parking depth (zone 2)	0	sec	0	3600	
PC 5 0 10	Sampling period in Parking Drift (zone 2)	0	min	0	3600	
PC 5 0 11	Sampling period in Descent To Profile Depth (zone 2)	0	sec	0	3600	
PC 5 0 12	Sampling period in Profile Depth Drift (zone 2)	0	min	0	3600	
PC 5 0 13	Sampling period in Ascent Profile (zone 2)	0	sec	0	3600	
PC 5 0 14	Power Acquisition Mode in zone 2 (0 : none, 2 : pulsed, 3 : continuous)	3		0	3	
PC 5 0 15	Treatment Type in zone 2 (0 : raw, 1 : average, 7 : Average/Median/Standard Deviation)	1		0	7	
PC 5 0 16	NOT USED	1		1	1	
PC 5 0 17	Slices Thickness for zone 2	5	dBars	1	500	
PC 5 0 18	Sampling period in descent to parking depth (zone 3)	0	sec	0	3600	
PC 5 0 19	Sampling period in Parking Drift (zone 3)	0	min	0	3600	
PC 5 0 20	Sampling period in Descent To Profile Depth (zone 3)	0	sec	0	3600	
PC 5 0 21	Sampling period in Profile Depth Drift (zone 3)	0	min	0	3600	
PC 5 0 22	Sampling period in Ascent Profile (zone 3)	0	sec	0	3600	
PC 5 0 23	Power Acquisition Mode in zone 3 (0 : none, 2 : pulsed, 3 : continuous)	3		0	3	
PC 5 0 24	Treatment Type in zone 3 (0 : raw, 1 : average, 7 : Average/Median/Standard Deviation)	1		0	7	
PC 5 0 25	NOT USED	1		1	1	
PC 5 0 26	Slices Thickness for zone 3	10	dBars	1	500	
PC 5 0 27	Sampling period in descent to parking depth (zone 4)	0	sec	0	3600	
PC 5 0 28	Sampling period in Parking Drift (zone 4)	0	min	0	3600	
PC 5 0 29	Sampling period in Descent To Profile Depth (zone 4)	0	sec	0	3600	
PC 5 0 30	Sampling period in Profile Depth Drift (zone 4)	0	min	0	3600	
PC 5 0 31	Sampling period in Ascent Profile (zone 4)	0	sec	0	3600	
PC 5 0 32	Power Acquisition Mode in zone 4 (0 : none, 2 : pulsed, 3 : continuous)	3		0	3	

PC 5 0 33	Treatment Type in zone 4 (0 : raw, 1 : average, 7 : Average/Median/Standard Deviation)	1		0	7	
PC 5 0 34	NOT USED	1		1	1	
PC 5 0 35	Slices Thickness for zone 4	20	dBars	1	500	
PC 5 0 36	Sampling period in descent to parking depth (zone 5)	0	sec	0	3600	
PC 5 0 37	Sampling period in Parking Drift (zone 5)	0	min	0	3600	
PC 5 0 38	Sampling period in Descent To Profile Depth (zone 5)	0	sec	0	3600	
PC 5 0 39	Sampling period in Profile Depth Drift (zone 5)	0	min	0	3600	
PC 5 0 40	Sampling period in Ascent Profile (zone 5)	0	sec	0	3600	
PC 5 0 41	Power Acquisition Mode in zone 5 (0 : none, 2 : pulsed, 3 : continuous)	3		3	3	
PC 5 0 42	Treatment Type in zone 5 (0 : raw, 1 : average, 7 : Average/Median/Standard Deviation)	1		0	7	
PC 5 0 43	NOT USED	1		1	1	
PC 5 0 44	Slices Thickness for zone 5	25	dBars	1	500	
PC 5 0 45	Threshold zone 1 / zone 2	10	dBars	1	2200	
PC 5 0 46	Threshold zone 2 / zone 3	200	dBars	1	2200	
PC 5 0 47	Threshold zone 3 / zone 4	500	dBars	1	2200	
PC 5 0 48	Threshold zone 4 / zone 5	1000	dBars	1	2200	

See [section 5.3.2](#) for standard parameters details.

5.3.9.2 CROVER Specific parameters

SPECIFIC SENSOR PARAMETERS (TYPE 1) – SENSOR 5 (cROVER)						
Abbr.	NAME	DEFAULT VALUE	UNIT	MIN VALUE	MAX VALUE	REQUEST VALUE
PC 5 1 0	Sensor Power Warm-up Time	1100	msec	0	65535	
PC 5 1 1	Power OFF time between Power ON retry	2000	msec	0	65535	
PC 5 1 2	1st «valid sample» rank	0		0	255	
PC 5 1 3	Number of raw data per slice in ECO mode	1		1	255	
PC 5 1 4	Min beam attenuation	-1	m ⁻¹	Mini float	Maxi float	
PC 5 1 5	Max beam attenuation	90	m ⁻¹	Mini float	Maxi float	
PC 5 1 6	Extrude acquisition during hydraulic pump activation	0		0	1	

See [section 5.3.3](#) for specific parameters details.

5.3.10 SUNA Parameters (Sensor “6”)

5.3.10.1 SUNA Standard parameters

STANDARD SENSOR PARAMETERS (TYPE 0) – SENSOR 6 (SUNA)						
Abbr.	NAME	DEFAULT VALUE	UNIT	MIN VALUE	MAX VALUE	REQUEST VALUE
PC 6 0 0	Sampling period in descent to parking depth (zone 1)	0	sec	0	3600	
PC 6 0 1	Sampling period in Parking Drift (zone 1)	0	min	0	3600	
PC 6 0 2	Sampling period in Descent To Profile Depth (zone 1)	0	sec	0	3600	
PC 6 0 3	Sampling period in Profile Depth Drift (zone 1)	0	min	0	3600	
PC 6 0 4	Sampling period in Ascent Profile (zone 1)	0	sec	0	3600	
PC 6 0 5	Power Acquisition Mode in zone 1 (0 : none, 2 : pulsed, 3 : continuous)	2		0	3	
PC 6 0 6	Treatment Type in zone 1 (0 : raw, 1 : average, 7 : Average/Median/Standard Deviation)	0		0	7	
PC 6 0 7	NOT USED	1		1	1	
PC 6 0 8	Slices Thickness for zone 1	1	dBars	1	500	
PC 6 0 9	Sampling period in descent to parking depth (zone 2)	0	sec	0	3600	
PC 6 0 10	Sampling period in Parking Drift (zone 2)	0	min	0	3600	
PC 6 0 11	Sampling period in Descent To Profile Depth (zone 2)	0	sec	0	3600	
PC 6 0 12	Sampling period in Profile Depth Drift (zone 2)	0	min	0	3600	
PC 6 0 13	Sampling period in Ascent Profile (zone 2)	0	sec	0	3600	
PC 6 0 14	Power Acquisition Mode in zone 2 (0 : none, 2 : pulsed, 3 : continuous)	2		0	3	
PC 6 0 15	Treatment Type in zone 2 (0 : raw, 1 : average, 7 : Average/Median/Standard Deviation)	0		0	7	
PC 6 0 16	NOT USED	1		1	1	
PC 6 0 17	Slices Thickness for zone 2	5	dBars	1	500	
PC 6 0 18	Sampling period in descent to parking depth (zone 3)	0	sec	0	3600	
PC 6 0 19	Sampling period in Parking Drift (zone 3)	0	min	0	3600	
PC 6 0 20	Sampling period in Descent To Profile Depth (zone 3)	0	sec	0	3600	
PC 6 0 21	Sampling period in Profile Depth Drift (zone 3)	0	min	0	3600	
PC 6 0 22	Sampling period in Ascent Profile (zone 3)	0	sec	0	3600	
PC 6 0 23	Power Acquisition Mode in zone 3 (0 : none, 2 : pulsed, 3 : continuous)	2		0	3	
PC 6 0 24	Treatment Type in zone 3 (0 : raw, 1 : average, 7 : Average/Median/Standard Deviation)	0		0	7	
PC 6 0 25	NOT USED	1		1	1	
PC 6 0 26	Slices Thickness for zone 3	10	dBars	1	500	
PC 6 0 27	Sampling period in descent to parking depth (zone 4)	0	sec	0	3600	
PC 6 0 28	Sampling period in Parking Drift (zone 4)	0	min	0	3600	
PC 6 0 29	Sampling period in Descent To Profile Depth (zone 4)	0	sec	0	3600	
PC 6 0 30	Sampling period in Profile Depth Drift (zone 4)	0	min	0	3600	
PC 6 0 31	Sampling period in Ascent Profile (zone 4)	0	sec	0	3600	
PC 6 0 32	Power Acquisition Mode in zone 4 (0 : none, 2 : pulsed, 3 : continuous)	2		0	3	

PC 6 0 33	Treatment Type in zone 4 (0 : raw, 1 : average, 7 : Average/Median/Standard Deviation)	0		0	7	
PC 6 0 34	NOT USED	1		1	1	
PC 6 0 35	Slices Thickness for zone 4	20	dBars	1	500	
PC 6 0 36	Sampling period in descent to parking depth (zone 5)	0	sec	0	3600	
PC 6 0 37	Sampling period in Parking Drift (zone 5)	0	min	0	3600	
PC 6 0 38	Sampling period in Descent To Profile Depth (zone 5)	0	sec	0	3600	
PC 6 0 39	Sampling period in Profile Depth Drift (zone 5)	0	min	0	3600	
PC 6 0 40	Sampling period in Ascent Profile (zone 5)	0	sec	0	3600	
PC 6 0 41	Power Acquisition Mode in zone 5 (0 : none, 2 : pulsed, 3 : continuous)	2		3	3	
PC 6 0 42	Treatment Type in zone 5 (0 : raw, 1 : average, 7 : Average/Median/Standard Deviation)	0		0	7	
PC 6 0 43	NOT USED	1		1	1	
PC 6 0 44	Slices Thickness for zone 5	25	dBars	1	500	
PC 6 0 45	Threshold zone 1 / zone 2	10	dBars	1	2200	
PC 6 0 46	Threshold zone 2 / zone 3	200	dBars	1	2200	
PC 6 0 47	Threshold zone 3 / zone 4	500	dBars	1	2200	
PC 6 0 48	Threshold zone 4 / zone 5	1000	dBars	1	2200	

See [section 5.3.2](#) for standard parameters details.

5.3.10.2 SUNA Specific parameters

SPECIFIC SENSOR PARAMETERS (TYPE 1) – SENSOR 6 (SUNA)						
Abbr.	NAME	DEFAULT VALUE	UNIT	MIN VALUE	MAX VALUE	REQUEST VALUE
PC 6 1 0	Sensor Power Warm-up Time	5300	msec	0	65535	
PC 6 1 1	Power OFF time between Power ON retry	3000	msec	0	65535	
PC 6 1 2	1st «valid sample» rank	0		0	255	
PC 6 1 3	Number of raw data per slice in ECO mode	1		1	255	
PC 6 1 4	« APF Frame » Transmission	1		0	1	
PC 6 1 5	Min Concentration	Mini float		Mini float	Maxi float	
PC 6 1 6	Max Concentration	Maxi float	l	Mini float	Maxi float	
PC 6 1 7	Extrude acquisition during hydraulic pump activation	0		0	1	

“APF FRAME” Transmission : You can choose SUNA data type to be transmitted by float : Nitrate concentration (=0) or Spectrum (“APF Frame”) (=1). See [section 7.2.4.7](#) for more details regarding transmitted message format.

See [section 5.3.3](#) for specific parameters details.

5.4 Ice parameters (with firmware V3.00 and higher)

Parameter	Description	Default value	Unit	Min Value	Max Value
PG 0	Number of days without emergence	10		0	365
PG 1	Number of days to force emergence	90		0	365
PG 2	Number of detection (ISA) to confirm ICE at surface	3		1	10
PG 3	Slowdown pressure threshold (float's speed)	150	1 dBar	100	2100
PG 4	Pressure acquisition period during ascent		1 sec	1	50
PG 5	Minimum ascent speed during "slow ascent"	30	1 mm/sec	10	500
PG 6	Pump action duration	500	0.01 sec	500	2000
PG 7	GPS Timeout	10	1 Minute	3	60
PG 8	Max volume to detect ascent blocking	500	1 Cm3	10	3000

5.4.1 ICE parameters description

PG(0) Number of day without emergence

This number of days, is applied to forbid emergence once Ice detection is confirmed. During this number of days, even is Ice is not detected during ascent, float will not emerge and transmit.

PG0 = 0 means Ice detection is not active

PG(1) Number of day to force emergence

After 1st ice detection is confirmed, this mechanism enable float to force emergence and try to transmit. This security enables not to loose float in case of false ice detection for long period

PG(2) ISA detection number to confirm Ice at surface

Number of Ice detection during ascent to confirm Ice presence at surface.

PG(3) Slowdown pressure threshold (ascent speed decrease for slow ascent)

Once Pressure becomes inferior to this threshold, float will enters in "slow ascent with a reduced speed in order to monitor pressure for ISA algorithm.

PG(4) Pressure acquisition period during ascent

Delay between 2 pressure measurement to control float ascent speed

PG(5) Minimum ascent speed during "slow ascent"

Minimum ascent speed used for pump action during "slow ascent"

PG(6) Pump action duration

Pump action duration during "slow ascent". Replace PT 6 for normal ascent

PG(7) GPS session max duration

GPS maximum acquisition duration with Ice detection requested

PG(8) Volume to detect ascent hanging

Cumulated oil volume during ascent to detect hanging under ice

5.5 Rudics Parameters

Parameter	Description	Default value	Unit	Min Value	Max Value
PI 0	Phone Number	0			15 digits
PI 1	Login				15 characters
PI 2	Password				15 characters
PI 3	Session Time-out (in minutes)	60	1 minute	60	1440
PI 4	First hanging Time-out (in minutes)	30	1 minute	15	1440
PI 5	Full Auto-test (Rudics server connection test at mission begin)	1 (yes)		0 (no)	1 (yes)
PI 6	SBD positioning activation	0 (no)		0 (no)	1 (yes)
PI 7	Send SBD positioning only on GPS default	0 (no)		0 (no)	1 (yes)
PI 8	SBD positioning activation	0 (no)		0 (no)	1 (yes)
PI 9	Send SBD positioning only on GPS default	0 (no)		0 (no)	1 (yes)

PI(0) Phone Number

This is the phone number float will call to contact rudics server. CANNOT be modified by telecommand.

PI(1) Login

Login specific for each float. CANNOT be modified by telecommand.

PI(2) Password

Password for rudics server directory access. CANNOT be modified by telecommand.

PI(3) Session Time-Out

Maximum transmission period for one session.

PI(4) Delay Between Session Retries

Delay between each sessions retries. Session Time-out is comprised inside this timing

PI(5) Session Retries

Number of retries session.

PI(6) "Base64" Message encoding

Base64 encoding (1 = yes; 0 = no).

PI(7) Full Auto-test

Indicate if full auto-test is requested at float deployment. Full auto-test is recommended, in order to be sure all parameter are well programmed and also that transmission is OK (a connection to server is established with full auto-test. Float must be placed in satellite visibility.

PI(8) SBD positioning activation

Open a SBD Iridium session for each GPS fix to add a Iridium positioning.

PI(9) Send SBD positioning only on GPS default

Open a SBD Iridium session for a Iridium positioning only if GPS fix is invalid.

With firmware V3.00 and higher

Parameter	Description	Default value	Unit	Min Value	Max Value
PI 0	Phone Number	0			15 digits
PI 1	Login				15 characters
PI 2	Password				15 characters
PI 3	Session Time-out (in minutes)	60	1 minute	60	1440
PI 4	First hanging Time-out (in minutes)	30	1 minute	15	1440
PI 5	Full Auto-test (Rudics server connection test at mission begin)	1 (yes)		0 (no)	1 (yes)
PI 6	SBD positioning activation	0 (no)		0 (no)	1 (yes)
PI 7	Send SBD positioning only on GPS default	0 (no)		0 (no)	1 (yes)

PI(0) Phone Number

This is the phone number float will call to contact RUDICS server. CANNOT be modified by telecommand.

PI(1) Login

Login specific for each float. CANNOT be modified by telecommand.

PI(2) Password

Password for RUDICS server directory access. CANNOT be modified by telecommand.

PI(3) Session Time-Out

Maximum transmission period for one session.

PI(4) First hanging Time-Out

Maximum delay to establish a first RUDICS server connection.

PI(5) Full Auto-test

Indicate if full auto-test is requested at float deployment. Full auto-test is recommended, in order to be sure all parameter are well programmed and also that transmission is OK (a connection to server is established with full auto-test. Float must be placed in satellite visibility.

PI(6) SBD positioning activation

Open a SBD Iridium session for each GPS fix to add a Iridium positioning.

PI(7) Send SBD positioning only on GPS default

Open a SBD Iridium session for a Iridium positioning only if GPS fix is invalid.

5.5.1 Transmission strategy

Rudics transmission mode is based on the same packet format as the SBD transmission. SBD packets are created and transmitted in « message », with 1024 bytes message size. As SBD packet have 140 bytes size, 44 bytes are filled in with zero inside « 1024 bytes message ».

44 bytes (fill in with zero) = 1024 bytes (message size) - 140bytes(packet size) * 7 packets.

Then, because of Base64 encoding, each message size is only 700 byte (= 5 packet), instead of 980 bytes (= 7 packets). Base64 encoding transforms message from 700 bytes to 1024 bytes size

Data file name give timing information about transmission :

Data file name : `yymmjj_hhnnss_XXXXXX_XXXXX.bin` (created by the float and written on rudics server)

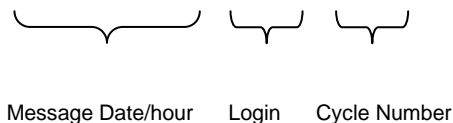

 Message Date/hour Login Cycle Number

5.5.2 Telecommands file

- Telecommand file must be placed in float's directory on Rudics Server, with following name : « RUDICS_cmd.txt ». This file must contains command list

example : `!PC 0 0 0 10`
 `!PC 0 0 1 0`

(all command must be followed by Carriage Return, even last command in file).

See [section 2.5.5](#) for command syntax details.

- File is read by the float then erase from the server.
- Command inside file are executed by float, then acknowledged by float in file created by float.

Ex : `!PC x → OK`

`!PH x → ERROR`

...

Created file (by float on Rudics server) : « `yymmjj_hhnnss_XXXXXX_RUDICS_cmd.txt` »



 Date/hour Login

N.B. : Date and hour in file name enable to know telecommand file history.

5.5.3 Retries strategy (unavailable with firmware V3.00 and higher)

Session Time-Out for Rudics transmission is given by Rudics parameter « PI 3 ». This limit enables float not to stay trying to transmit in case of worst conditions and delayed transmission.

Session can be repeated by using Rudics parameter "PI 5"

Once Timing for transmission is reached, if message need to be transmitted, a delay is applied before new session (set by rudics parameter « PI 4 »). If retries number is reached and transmission is not ended, float will enter new cycle, without transmitting remaining data on cycle.

Example :

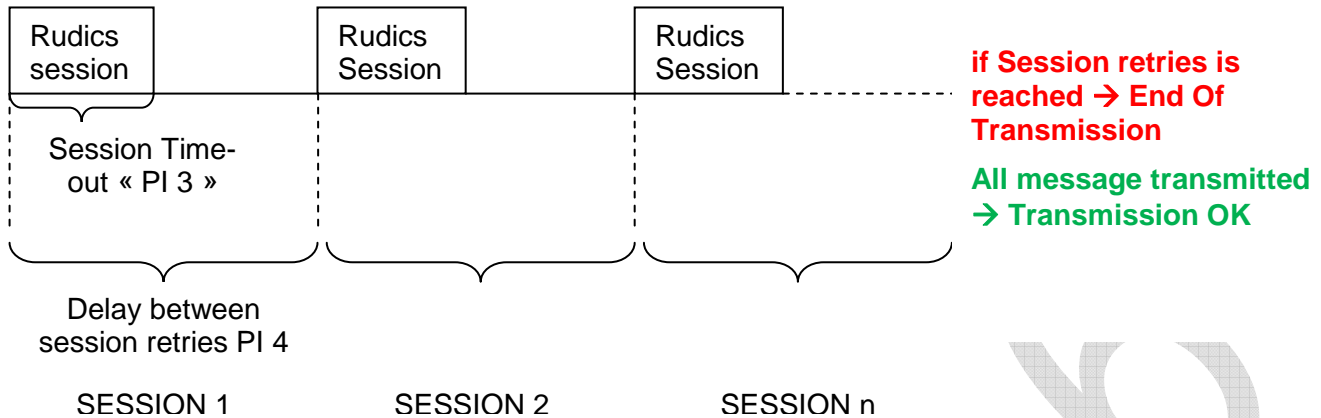

n is given by « PI 5 »

5.5.4 How to read Rudics parameter

To read Rudics parameter, send the command :

?PI

Float will answer :

*****RUDICS PARAMETERS*****

Phone Number : xxxxxxxxxxxxxx

Login : yyyyyyy

Password : zzzzzzzzz

Duration max of transmission : 50 minute(s)

Duration max for a first connection : 15 minute(s)

AUTOTEST

Full Auto-test : Yes

SBD POSITIONING

SBD Positioning : Activated : No

SBD Positioning : Send SBD only on GPS default\r\n(On GPS default=Yes, Send systematically = No) : No

<PI 0 xxxxxxxxxxxxxx >

<PI 1 yyyyyyy >

<PI 2 zzzzzzzzz >

<PI 3 60>

<PI 4 15>

<PI 5 1>

<PI 6 0>

<PI 7 0>

See [section 6](#) for details about User commands syntax and explanations

Rudics parameter 0, 1 and 2 cannot be modified with telecommand once the float has been deployed.

6 USER COMMANDS

Command	Rôle
!Cx	Float complete auto-test (CPU + measure board). X = 0 or 1. Is X=1, a complete auto-test is done (with ftp server connection). If x=0, serve connection is not done (used in laboratory for example)
!CH	Measure Board Auto-test (Sensor)
!SE	Initiate Iridium transmission session
!PM x y	Set value y for "mission parameter" x
?PM	Screen all mission parameters
?PM x	Screen mission parameter x
!PT x y *	Set value y for "technical parameter" x
?PT *	Screen all technical parameters
?PT x *	Screen technical parameter x
!PV x y	Set value y for "vector parameter" x
?PV	Screen all vector parameters
?PV x	Screen vector parameter x
!PC w x y z **	Set value z (sensor w) for parameter number y (x=0 for standard parameter, x=1 for specific parameter)
?PC x	Request sensor parameter for sensor x
?PC x y z	Request parameter z for sensor x (standard parameter if y=0, specific parameter if y=1)
!PI x y	Set value y for "Rudics parameter" x
?PI	Screen all Rudics parameters
?PI x	Screen Rudics parameter x
!SH x	Activate (x=1) or de-activate (x=0) Vector Show mode (MUST BE OFF FOR DEPLOYMENT)
?SH	Request show mode state
!TI jj mm aa hh mn ss	Set date and time to dd/mm/yy hh H : mn M : ss S
?TI	Request date and time for both CPU and measure board
?DH	Read all hydraulic data (pump and electrovalve activations)
?DT ALL x	Read all Treated Data for sensor x
?DB	Read all Raw Data for sensor x
!E x	Activate electrovalve for x cs (ctrl-c to stop)
!P x	Activate pump for x cs (ctrl-c to stop)
?ME x ***	Sensor x acquisition. X to identify sensor to be acquired
?VB	Request internal vacuum and battery voltage (in decivolt and millibars)

!AR x ****	Arm float (x=1) or deactivate arm mode (x=0)****
?AR	Request arm state
!RP	Parameters are transferred from EEPROM memory to RAM memory
!PO	Request GPS position
?VL	Request software version
?NS	Request float's serial number
!KV x	Command to activate or deactivate read/Write access for technical parameters. X value is communicated to users upon request to nke
!KC x	Command to activate or deactivate read/Write access for Sensors parameters. X value is communicated to users upon request to nke
!RV ****	External bladder is filled-in with Oil up to full position (float must be in vertical position)
?RE	Read the 5 last reset date and time
!PB	Request Battery Voltage with hydraulic pump active

* : protected command (need !KV 1234 to unlock)

** : protected command (need !KC 1234 to unlock)

*** : **Sensor type** :

0 = CTD, 1 = Optode, 2 = OCR504 , 3 = ECO3, 4 = FLNTU, 5 = cROVER, 6 = SUNA

**** : As Armed Mode command is sent to float, float performs auto-test, and fill in external bladder, by activate hydraulic pump. Floats can pump up to several minutes depending on external bladder initial state.

7 IRIDIUM FORMATS

7.1 Transmission strategy

Iridium format consists in transmitting file by rudics or SBD (size up to 1960 bytes in SBD mode and 1024 bytes in Rudics mode) coded in hexadecimal. Several messages can be necessary for a complete cycle transmission. Transmission mode must request during float order, as both mode are not yet implemented.

Messages are divided into elementary Packet (size 140 bytes). Maximum message contains 14 packets (SBD mode), 5 packets (Rudics mode with Base64 encoding) or 7 packets (Rudics mode without Base64 encoding).

1) SBD Packet creation then Message creation

Packet Type 0
Packet Type 255
Packet Type 254
Packet Type 253
Packet Type 252
Packet Type 251
Packet Type 250
Packet Type 2xx (free)

1960 bytes message N°1 sent

⇒ 1960 bytes message N°2 sent

1960 bytes message N°n sent

Note : Last message for a complete transmission session can be shorter than 1960 bytes.

2) Rudics Packet creation then Message creation (without optimization)

Packet Type 0
Packet Type 255
Packet Type 254
Packet Type 253
Packet Type 252

700 bytes message N°1

1024 bytes message N°1

1024 bytes message N°2

1024 bytes message N°n

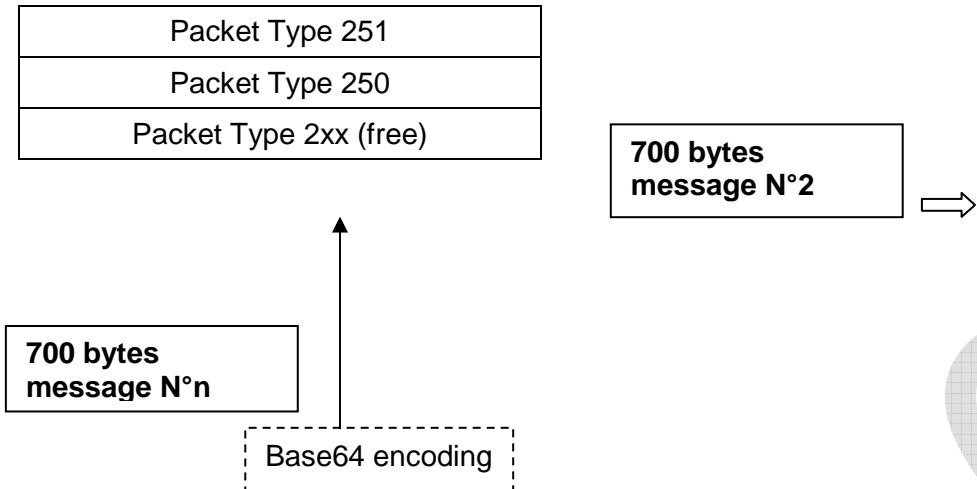

With Rudics transmission mode, each message is encoded with base64 algorithm before transmission

2) Rudics Packet creation then Message creation (with optimization)

Firmware V3.00 and higher

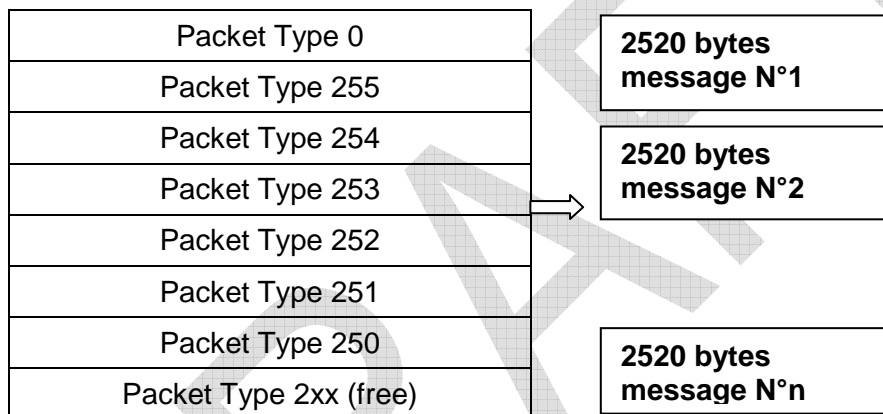

With optimized mode, there is no more Base 64 encoding

2) SBD Transmission Strategy

1960 BYTES MESSAGE

↓ 10 transmission tries (PT25) for one message, then Modem is powered OFF and ON, then 10 others transmission tries (2 power Commutations). If transmission is not OK, message size is divided by 2 size 980 bytes

980 BYTES MESSAGE → 980 BYTES MESSAGE

↓ 10 transmission tries (PT25) for one message, then Modem is powered OFF and ON, then 10 others transmission tries (2 power Commutations). If transmission is not OK, message size is divided to 420 bytes (3 packet)

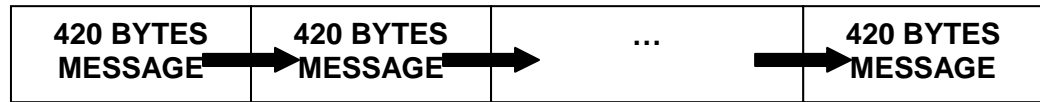

10 transmission tries (PT25) for one message, then Modem is powered OFF and ON, then 10 others transmission tries (2 power Commutations). If transmission is not OK, message size is reduced 140 bytes (1 packet)

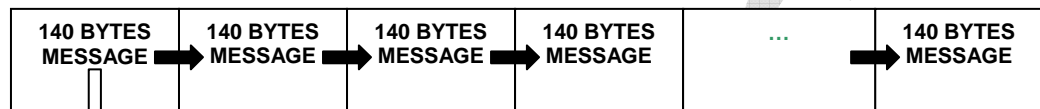

Transmission aborted (Data of cycle are lost)

Note : message size go back to superior size if transmission succeed.

7.2 Packet Structure

All packets have same structure :

Packet Type (1 byte)	Sensor Data type (1 byte)	Data field (138 bytes)
---	--	---------------------------

7.3 Packet Types

Packet number	Packet Type (see "Sensors Data Type" section for description)
0	Sensor Data
...	Not used
248	Rudics parameters
249	Sensor parameters (firmware V3.00 & higher)
250	Sensor Technical Data
251	PC Sensor Parameters
252	Vector Pressure Data
253	Vector Technical Data
254	PT Technical parameters & PG Ice parameters (firmware V3.00 & higher)
255	PV & PM Parameters

7.3.1 Sensor Data type

In Data packet (Packet type = 0), the field « Sensor data type » give the format of message, depending on transmitted sensor and treatment type (depending on [PC parameter](#)).

Per sensor, it is possible to request different treatment, so different "Sensor Data type" depending on pressure range in the water column.

Sensor Data Type	Data Type
0	CTD (Average)

1	CTD (Standard deviation+ Median)
2	CTD (Raw data)
3	Oxygen (Average)
4	Oxygen (Standard deviation+ Median)
5	Oxygen (Raw data)
6	ECO2 (Average)
7	ECO2 (Standard deviation + Median)
8	ECO2 (Raw data)
9	ECO3 (Average)
10	ECO3 (Standard deviation + Median)
11	ECO3 (Raw data)
12	OCR (Average)
13	OCR (Standard deviation + Median)
14	OCR (Raw data)
15	FLNTU (Average)
16	FLNTU (Standard deviation + Median)
17	FLNTU (Raw data)
18	cROVER (Average)
19	cROVER (Standard deviation + Median)
20	cROVER (Raw data)
21	SUNA (Average)
22	SUNA (Standard deviation + Median)
23	SUNA (Raw data)
24	SUNA (APF Frame)
25	SUNA (APF Frame 2)

7.3.2 Phase description

All transmitted data are acquired during different phase in the cycle, here the description for each phase (included in all message in data field)

Phase number	Phase Name	Description
0	Pre-mission	Mission beginning (1st Iridium session)
1	Surface Waiting	Float wait's at surface between 2 iridium session (if PV2 is not null)
2	Init new cycle	Float computes all timing for next cycle
3	Init new profile	Float computes all timing for next profile
4	Buoyancy reduction	Float descending phase at surface (up to PT specific threshold)
5	Descent to parking pressure	Float descend to Parking Pressure depth
6	Parking Drift	
7	Descent to profile pressure	
8	Drift at Profile Depth	
9	Ascent Profile	
10	Emergence	Float activate hydraulic pump to inflate external bladder to get enough buoyancy for Satellite transmission
11	Data treatment	Float computes all calculations on raw data for transmission phase
12	Satellite transmission	Float transmit all sensor and technical packets
13	End of Profile	
14	End Of Life	Float has reached programmed number of cycle
15	Emergency ascent	Float ascent to surface in case of trouble
16	User Dialog Mode	Float is not yet on mission, waiting for User command by Bluetooth
17	Buoyancy inversion	Float detect ice and dive faster as possible

7.3.3 Coding format

For coding all information inside packet, different coding format will be used :

Coding Format	abreviation	Coding range
Unsigned Char	(UC)	[0;255]
Signed char	(CHAR)	[-128 ; 127]
Unsigned int	(UI)	[0 ; 65 535]
Signed int	(INT)	[-32 768 ; 32 767]
Unsigned Long Int	(U LONG INT)	[0 ; 4 294 967 295]
Long Int	(LONG INT)	[-2 147 483 648 ; 2 147 483 647]
Float	(F)	[3.4*10e-38 ; 3.4 * 10e38]

7.3.4 Packets Formats

7.3.4.1 Packet type 0 - Sensor data type 0, 1 & 2 - CTD Data

Resolution :

- Pressure : in cBar (with 1000cBar offset with firmware V3.00 and higher)
- Temperature : in m°C with 2000m°C offset (except for standard deviation).
- Salinity : in mPSU
- Date and Hour : number of seconds since 1st january 2000

7.3.4.1.1 Sensor Data Type 0 : CTD (Average)

Data	Format (bytes)	Format (coding)
<u>Packet Type</u> : 0	1	UC
<u>Sensor Data Type</u> : 0	1	UC
Cycle number	2	UI
Profile Number	1	UC
<u>Phase Number</u>	1	UC
1 st Sample Date & Hour	4	U LONG INT
1 st Sample « Average Pressure »	2	INT
1 st Sample « Average Temperature»	2	UI
1 st Sample « Average Salinity »	2	UI
2 nd to 21 st Data blocks	(2+2+2)*20	
Complement (bits to zero)	4	
Total	140	

7.3.4.1.2 Sensor Data Type 1 : CTD (Standard deviation+ Median)

Data	Format (bytes)	Format (coding)
<u>Packet Type</u> : 0	1	UC
<u>Sensor Data Type</u> : 1	1	UC
Cycle number	2	UI
Profile Number	1	UC
<u>Phase Number</u>	1	UC
1 st Sample Date & Hour	4	U LONG INT
1 st Sample « Mean Pressure »	2	INT
1 st Sample « standard deviation temperature » (no offset)	1	UC
1 st Sample « standard deviation salinity »	1	UC
1 st Sample « Median Pressure »	2	INT
1 st Sample « Median temperature »	2	UI
1 st Sample « Median salinity »	2	UI
2 nd to 13th Data block	(2+1+1+2+2+2) * 12	
Total	140	

7.3.4.1.3 Sensor Data Type 2 : CTD (Raw Data)

Data	Formats (bytes)	Format (coding)
<u>Packet Type: 0</u>	1	UC
<u>Sensor Data Type : 2</u>	1	UC
Cycle number	2	UI
Profile Number	1	UC
<u>Phase Number</u>	1	UC
1 st Sample Date & Hour	4	U LONG INT
1 st Sample « Average Pressure »	2	INT
1 st Sample « Average Temperature »	2	UI
1 st Sample « Average Salinity »	2	UI
2 nd to 21 st Data blocks	(2+2+2)*20	
Complement (bits to zero)	4	
Total	140	

DRAFT

7.3.4.2 Packet type 0 – Sensor Data type 3, 4 & 5 - Oxygen Sensor data

Resolution :

- Pressure : in cBar (with 1000cBar offset with firmware V3.00 and higher)
- C1/C2 Phase : in millidegrees
- Temperature : in m°C with a 2000m°C offset (except for standard deviation)
- Date and Hour : number of seconds since 1st january 2000

7.3.4.2.1 Sensor Data Type 3 : Oxygen (Average)

Data	Format (bytes)	Format (coding)
Packet Type: 0	1	UC
Sensor Data type : 3	1	UC
Cycle number	2	UI
Profile Number	1	UC
Phase Number	1	UC
1 st Sample Date & Hour	4	U LONG INT
1 st Sample « Mean Pressure »	2	INT
1 st Sample « C1 Phase »	4	LONG INT
1 st Sample « C2 Phase »	4	LONG INT
1 st Sample « temperature »	2	UI
2 nd to 10 th Data blocks	$(2+4+4+2) * 9$	
Complement	10	
Total	140	

7.3.4.2.2 Sensor Data Type 4 : Oxygen (Standard deviation+ Median)

Data	Format (bytes)	Format (coding)
Packet Type: 0	1	UC
Sensor Data Type : 4	1	UC
Cycle number	2	UI
Profile Number	1	UC
Phase Number	1	UC
1 st Sample Date & Hour	4	U LONG INT
1 st Sample « Mean Pressure »	2	INT
1 st Sample « standard deviation C1 Phase »	2	UI
1 st Sample « standard deviation C2 Phase »	2	UI
1 st Sample « standard deviation Temperature » (no offset)	1	UC
1 st Sample « Median C1 Phase »	4	LONG INT
1 st Sample « Median C2 Phase »	4	LONG INT
1 st Sample « Median Temperature »	2	UI
2 nd to 7 th Data blocks	$(2+2+2+1+4+4+2) * 6$	
Complement	11	
Total	140	

7.3.4.2.3 Sensor Data Type 5 : Oxygen (Raw data)

Data	Format (bytes)	Format (coding)
<u>Packet Type</u> : 0	1	UC
<u>Sensor Data type</u> : 5	1	UC
Cycle number	2	UI
Profile Number	1	UC
<u>Phase Number</u>	1	UC
1 st Sample Date & Hour	4	U LONG INT
1 st Sample « Mean Pressure »	2	INT
1 st Sample « C1 Phase »	4	LONG INT
1 st Sample C2 Phase »	4	LONG INT
1 st Sample « temperature »	2	UI
2 nd to 10 th Data blocks	$(2+4+4+2) * 9$	
Complement	10	
Total	140	

DRAFT

7.3.4.3 Packet type 0 – Sensor Data Type 6, 7 & 8 – ECO2 Data

Resolution :

- Pressure : in cBar (with 1000cBar offset with firmware V3.00 and higher)
- Channel : in « Count » * 10
- Date and Hour : number of seconds since 1st january 2000

7.3.4.3.1 Sensor Data Type 6 : ECO2 (Average)

Data	Format (bytes)	Format (coding)
<u>Packet Type</u> : 0	1	UC
<u>Sensor Data Type</u> : 6	1	UC
Cycle number	2	UI
Profile Number	1	UC
<u>Phase Number</u>	1	UC
1 st Sample Date & Hour	4	U LONG INT
1 st Sample « Mean Pressure »	2	INT
1 st Sample « Channel 1 »	2	UI
1 st Sample « Channel 2 »	2	UI
2 ^{ème} to 21 th data Blocks (pressure, Channel 1, Channel 2)	(2+2+2) * 20	
Complement	4	
Total	140	

7.3.4.3.2 Sensor Data Type 7 : ECO2 (Standard Deviation+ Median)

Data	Format (bytes)	Format (coding)
<u>Packet Type</u> : 0	1	UC
<u>Sensor Data Type</u> : 7	1	UC
Cycle number	2	UI
Profile Number	1	UC
<u>Phase Number</u>	1	UC
1 st Sample Date & Hour	4	U LONG INT
1 st Sample « Mean Pressure »	2	INT
1 st Sample « standard deviation Channel 1 »	1	UC
1 st Sample « standard deviation Channel 2 »	1	UC
1 st Sample « Median Channel 1 »	2	UI
1 st Sample « Median Channel 2 »	2	UI
2 nd to 16 th data Blocks	(2+1+1+2+2)* 10	
Complement	2	
Total	140	

7.3.4.3.3 Sensor Data Type 8 : ECO2 (Raw data)

Data	Format (bytes)	Format (coding)
<u>Packet Type</u> : 0	1	UC
<u>Sensor Data Type</u> : 8	1	UC
Cycle number	2	UI
Profile Number	1	UC
<u>Phase Number</u>	1	UC
1 st Sample Date & Hour	4	U LONG INT
1 st Sample « Mean Pressure »	2	INT
1 st Sample « Channel 1 »	2	UI
1 st Sample « Channel 2 »	2	UI
2 nd to 21 th data Blocks (pressure, Channel 1, Channel 2)	$(2+2+2) * 20$	
Complement	4	
Total	140	

DRAFT

7.3.4.4 Packet type 0 – Sensor Data Type 9, 10 & 11 - ECO3 Data

Resolution :

- Pressure : in cBar (with 1000cBar offset with firmware V3.00 and higher)
- Chlorophylla : in « Count » * 10
- Backscatter : in « Count » * 10
- CDOM : in « Count » * 10
- Date and Hour : number of seconds since 1st january 2000

7.3.4.4.1 Sensor Data Type 9 : ECO3 (Average)

Data	Format (bytes)	Format (coding)
<u>Packet Type</u> : 0	1	UC
<u>Sensor Data Type</u> : 9	1	UC
Cycle number	2	UI
Profile Number	1	UC
<u>Phase Number</u>	1	UC
1 st Sample Date & Hour	4	U LONG INT
1 st Sample « Mean Pressure »	2	INT
1 st Sample « Chlorophyll a »	2	UI
1 st Sample « Backscatter »	2	UI
1 st Sample « CDOM »	2	UI
2 ^{ème} to 16 th data Blocks (pressure, Chlorophyll a, Backscatter & CDOM)	(2+2+2+2) * 15	
Complement	2	
Total	140	

7.3.4.4.2 Sensor Data Type 10 : ECO3 (Standard Deviation+ Median)

Data	Format (bytes)	Format (coding)
<u>Packet Type</u> : 0	1	UC
<u>Sensor Data Type</u> : 10	1	UC
Cycle number	2	UI
Profile Number	1	UC
<u>Phase Number</u>	1	UC
1 st Sample Date & Hour	4	U LONG INT
1 st Sample « Mean Pressure »	2	INT
1 st Sample « standard deviation Chlorophyll a »	1	UC
1 st Sample « standard deviation Backscatter »	1	UC
1 st Sample « standard deviation CDOM »	1	UC
1 st Sample « Median Chlorophylla »	2	UI
1 st Sample « Median Backscatter »	2	UI
1 st Sample « Median CDOM »	2	UI
2 nd to 11 th data Blocks	(2+2+2+1+1+1+2)* 10	
Complement	9	
Total	140	

7.3.4.4.3 Sensor Data Type 11 : ECO3 (Raw data)

Data	Format (bytes)	Format (coding)
<u>Packet Type</u> : 0	1	UC
<u>Sensor Data Type</u> : 11	1	UC
Cycle number	2	UI
Profile Number	1	UC
<u>Phase Number</u>	1	UC
1 st Sample Date & Hour	4	U LONG INT
1 st Sample « Mean Pressure »	2	INT
1 st Sample « Chlorophyll a »	2	UI
1 st Sample « Backscatter »	2	UI
1 st Sample « CDOM »	2	UI
2 nd to 16 th data Blocks (pressure, Chlorophyll a, Backscatter and CDOM)	(2+2+2+2) * 15	
Complement	2	
Total	140	

DRAFT

7.3.4.5 Packet type 0 – Sensor Data Type 12, 13 & 14 - OCR Data

Irradiance range is included between 0x00000000 and 0xFFFFFFFFE.

Value 0xFFFFFFFF indicates an error.

Resolutions :

- Pressure : in cBar (with 1000cBar offset with firmware V3.00 and higher)
- Irradiance : in « count »
- Date and Hour : number of seconds since 1st january 2000

7.3.4.5.1 Sensor Data Type 12 : OCR (Average)

Data	Format (bytes)	Format (coding)
<u>Packet Type</u> : 0	1	UC
<u>Sensor Data type</u> : 12	1	UC
Cycle number	2	UI
Profile number	1	UC
<u>Phase number</u>	1	UC
1 st Sample Date & Hour	4	U LONG INT
1 st Sample « Mean pressure»	2	INT
1 st Sample « Irradiance_1 »	4	U LONG INT
1 st Sample « Irradiance_2 »	4	U LONG INT
1 st Sample « Irradiance_3 »	4	U LONG INT
1 st Sample « Irradiance_4 »	4	U LONG INT
2 nd to 7 th data Blocks pressure + Irradiance_x	6 * (4+4+4+4+2)	
Complement	4	
Total	140	

7.3.4.5.2 Sensor Data Type 13 : OCR (Standard Deviation+ Median)

Data	Format (bytes)	Format (coding)
<u>Packet Type</u> : 0	1	UC
<u>Sensor Data type</u> : 13	1	UC
Cycle number	2	UI
Profile number	1	UC
<u>Phase number</u>	1	UC
1 st Sample Date & Hour	4	U LONG INT
1 st Sample « Mean Pressure »	2	INT
1 st Sample « standard deviation Irradiance_1 »	4	U LONG INT
1 st Sample « standard deviation Irradiance_2 »	4	U LONG INT
1 st Sample « standard deviation Irradiance_3 »	4	U LONG INT
1 st Sample « standard deviation Irradiance_4 »	4	U LONG INT
1 st Sample « Median Irradiance_1 »	4	U LONG INT
1 st Sample « Median Irradiance_2 »	4	U LONG INT
1 st Sample « Median Irradiance_3 »	4	U LONG INT

1 st Sample « Median Irradiance_4 »	4	U LONG INT
2 nd to 3rd data Blocks	2 * (4*8+2)	
Complement	28	
Total	140	

7.3.4.5.3 Sensor Data Type 14 : OCR (Raw Data)

Data	Format (bytes)	Format (coding)
<u>Packet Type</u> : 0	1	UC
<u>Sensor Data type</u> : 14	1	UC
Cycle number	2	UI
Profile number	1	UC
<u>Phase number</u>	1	UC
1 st Sample Date & Hour	4	U LONG INT
1 st Sample « Mean pressure »	2	INT
1 st Sample « Irradiance_1 »	4	U LONG INT
1 st Sample « Irradiance_2 »	4	U LONG INT
1 st Sample « Irradiance_3 »	4	U LONG INT
1 st Sample « Irradiance_4 »	4	U LONG INT
2 nd to 7 th data Blocks pressure + Irradiance_x	6 * (4+4+4+4+2)	
Complement	4	
Total	140	

7.3.4.6 Packet type 0 – Sensor Data Type 15, 16 & 17 - FLNTU Sensor Data

Resolution :

- Pressure : in cBar (with 1000cBar offset with firmware V3.00 and higher)
- Chlorophyll : in « Count » * 10
- Turbidity : in « Count » * 10
- Date and Hour : number of seconds since 1st january 2000

7.3.4.6.1 Sensor Data Type 15 : FLNTU (Average)

Data	Format (bytes)	Format (coding)
<u>Packet Type: 0</u>	1	UC
<u>Sensor Data type : 15</u>	1	UC
Cycle number	2	UI
Profile Number	1	UC
<u>Phase Number</u>	1	UC
1 st Sample Date & Hour	4	U LONG INT
1 st Sample « Mean Pressure»	2	INT
1 st Sample « Chlorophyll »	2	UI
1 st Sample « Turbidity »	2	UI
2 nd to 21 st data blocks (Pressure, Chlorophyll, Turbidity)	(2+2+2) * 20	
Complement	4	
Total	140	

7.3.4.6.2 Sensor Data Type 16 : FLNTU (Standard deviation+ Median)

Data	Format (bytes)	Format (coding)
<u>Packet Type: 0</u>	1	UC
<u>Sensor Data type : 16</u>	1	UC
Cycle number	2	UI
Profile Number	1	UC
<u>Phase Number</u>	1	UC
1 st Sample Date & Hour	4	U LONG INT
1 st Sample « Mean Pressure»	2	INT
1 st Sample « standard deviation Chlorophyll»	1	UC
1 st Sample « standard deviation Turbidity »	1	UC
1 st Sample « Median Chlorophyll»	2	UI
1 st Sample « Median Turbidity »	2	UI
2 nd to 16 th data blocks	(2+1+1+2+2) * 15	
Complement	2	
Total	140	

7.3.4.6.3 Sensor Data Type 17 : FLNTU (raw data)

Data	Format (bytes)	<u>Format (coding)</u>
<u>Packet Type</u> : 0	1	UC
<u>Sensor Data type</u> : 17	1	UC
Cycle number	2	UI
Profile Number	1	UC
<u>Phase Number</u>	1	UC
1 st Sample Date & Hour	4	U LONG INT
1 st Sample « Mean Pressure »	2	INT
1 st Sample Chlorophyll »	2	UI
1 st Sample « Turbidity »	2	UI
2 nd to 21 st data Block (pressure, Chlorophyll and Turbidity)	$(2+2+2) * 20$	
Complement	4	
Total	140	

DRAFT

7.3.4.7 Packet type 0 – Sensor Data Type 18, 19 & 20 - CROVER Data

resolutions :

- Pressure : in cBar (with 1000cBar offset with firmware V3.00 and higher)
- Beam attenuation : $x * 1000$ (x in meter -1)
- Date and Hour : number of seconds since 1st january 2000

7.3.4.7.1 Sensor Data Type 18 : cROVER (Average)

Data	Format (bytes)	Format (coding)
<u>Packet Type</u> : 0	1	UC
<u>Sensor Data type</u> : 18	1	UC
Cycle number	2	UI
Profile Number	1	UC
<u>Phase Number</u>	1	UC
1 st Sample Date & Hour	4	U LONG INT
1 st Sample « Mean Pressure »	2	INT
1 st Sample « beam attenuation »	4	LONG INT
2 nd to 21 st data Block (pressure, Coef)	$(2+4) * 20$	
Complement	4	
Total	140	

7.3.4.7.2 Sensor Data Type 19 : cROVER (Standard Deviation+ Median)

Data	Format (bytes)	Format (coding)
<u>Packet Type</u> : 0	1	UC
<u>Sensor Data type</u> : 19	1	UC
Cycle number	2	UI
Profile Number	1	UC
<u>Phase Number</u>	1	UC
1 st Sample Date & Hour	4	U LONG INT
1 st Sample « Mean Pressure »	2	INT
1 st Sample « Standard deviation beam attenuation »	2	UI
1 st Sample « Median beam attenuation »	4	LONG INT
2 nd to 16 th data Blocks	$(2+4+2) * 15$	
Complement	2	
Total	140	

7.3.4.7.3 Sensor Data Type 20: cROVER (Raw Data)

Data	Format (bytes)	<u>Format (coding)</u>
<u>Packet Type</u> : 0	1	UC
<u>Sensor Data type</u> : 20	1	UC
Cycle number	2	UI
Profile Number	1	UC
<u>Phase Number</u>	1	UC
1 st Sample Date & Hour	4	ULI
1 st Sample « Mean Pressure »	2	INT
1 st Sample « beam attenuation »	4	LONG INT
2 nd to 21 st data Blocks (pressure, Coef)	(2+4) * 20	
Complement	4	
Total	140	

DRAFT

7.3.4.8 Packet type 0 – Sensor Data Type 21, 22, 23, 24 & 25 - SUNA Data

Resolutions :

- Pressure : in cBar (with 1000cBar offset with firmware V3.00 and higher)
- Concentration nitrate : x * 100
- Date and Hour : number of seconds since 1st january 2000

7.3.4.8.1 Sensor Data Type 21 : SUNA (Average)

Data	Format (bytes)	Format (coding)
<u>Packet Type</u> : 0	1	UC
<u>Sensor Data type</u> : 21	1	UC
Cycle number	2	UI
Profile Number	1	UC
<u>Phase Number</u>	1	UC
1 st Sample Date & Hour	4	ULI
1 st Sample « Mean Pressure »	2	INT
1 st Sample « Concentration nitrate »	4	FLOAT
2 nd to 21 st data Blocks (pressure, Concentration)	(2+4) * 20	
Complement	4	
Total	140	

7.3.4.8.2 Sensor Data Type 22 : SUNA (Standard Deviation+ Median)

Data	Format (bytes)	Format (coding)
<u>Packet Type</u> : 0	1	UC
<u>Sensor Data type</u> : 22	1	UC
Cycle number	2	UI
Profile Number	1	UC
<u>Phase Number</u>	1	UC
1 st Sample Date & Hour	4	ULI
1 st Sample « Mean Pressure »	2	INT
1 st Sample « Standard deviation Concentration nitrate »	2	UI
1 st Sample « Median Concentration nitrate »	4	FLOAT
2 nd to 16 th data Blocks	(2+4+2) * 15	
Complement	2	
Total	140	

7.3.4.8.3 Sensor Data Type 23 : SUNA (Raw Data)

Data	Format (bytes)	Format (coding)
<u>Packet Type</u> : 0	1	UC
<u>Sensor Data type</u> : 23	1	UC
Cycle number	2	UI
Profile Number	1	UC
<u>Phase Number</u>	1	UC
1 st Sample Date & Hour	4	ULI
1 st Sample « Mean Pressure»	2	INT
1 st Sample « Nitrate Concentration»	4	FLOAT
2 nd to 21 st data Blocks (pressure, Concentration)	(2+4) * 20	
Complement	4	
Total	140	

7.3.4.8.4 Sensor Data Type 24 : SUNA (APF Frame)

Data	Format (bytes)	Format (coding)	
<u>Packet Type</u> : 0	1	UC	
<u>Sensor Data type</u> : 24	1	UC	
Cycle number	2	UI	
Profile Number	1	UC	
<u>Phase Number</u>	1	UC	
Sample Date & Hour	4	ULI	
APF Frame	CTD Pressure	4	FLOAT
	CTD Temperature	4	FLOAT
	CTD Salinity	4	FLOAT
	Internal Temperature	4	FLOAT
	Spectrometer Temperature	4	FLOAT
	Internal Relative Humidity	4	FLOAT
	Dark Spectrum Mean	4	FLOAT
	Dark Spectrum Standard Deviation	4	FLOAT
	Sensor Nitrate	4	FLOAT
	Absorbance Fit Residuals	4	FLOAT
	Output Spectrum (from 1 to 45 pixels)	45 * 2	45 * UI
	Total	140	

7.3.4.8.5 Sensor Data Type 25: SUNA (APF Frame 2)

The APF frame 2 packet is generated if the SUNA's spectrum is too big to be sent only with the APF frame 1 packet.

Example : For SUNA configured to deliver data such as nitrate and H2S in the same spectrum.

Data		Format (bytes)	Format (coding)
<u>Packet Type</u> : 0		1	UC
<u>Sensor Data type</u> : 25		1	UC
Cycle number		2	UI
Profile Number		1	UC
<u>Phase Number</u>		1	UC
Sample Date & Hour		4	ULI
APF Frame	CTD Pressure	4	FLOAT
	CTD Temperature	4	FLOAT
	CTD Salinity	4	FLOAT
	Internal Temperature	4	FLOAT
	Spectrometer Temperature	4	FLOAT
	Internal Relative Humidity	4	FLOAT
	Dark Spectrum Mean	4	FLOAT
	Dark Spectrum Standard Deviation	4	FLOAT
	Sensor Nitrate	4	FLOAT
	Absorbance Fit Residuals	4	FLOAT
	Output Spectrum (form 46 to 90 pixels)	45 * 2	45 * UI
	Total		140

7.3.4.9 Packet Type 255 (Vector & Mission Parameters)

data	Format (bytes)	Format (coding)
<u>Packet Type: 255</u>	1	UC
Packet Date/Hour (Day, month, Year, hour, minute, second)	6*1	6 * UC
Cycle Number	2	UI
Profile Number	1	UC
PV 0 - Number of different cycle durations (1 to 5)	1	UC
PV 1 - Iridium End Of Life Period(min)	2	UI
PV 2 - Iridium 2 nd session waiting time (min)	1	UC
PV 3 - Cycle Period1 (in hours)	2	UI
PV 4,5 &6 - End date for Duration1 (Day, Month, Year)	3 * 1	3 * UC
PV 7 - Cycle Period2 (in hours)	2	UI
PV 8, 9 & 10 - End date for Duration2 (Day, Month, Year)	3 * 1	3 * UC
PV 11 - Cycle Period3 (in hours)	2	UI
PV 12, 13 & 14 - End date for Duration3 (Day, Month, Year)	3 * 1	3 * UC
PV 15 - Cycle Period4 (in hours)	2	UI
PV 16, 17 & 18 - End date for Duration4 (Day, Month, Year)	3 * 1	3 * UC
PV 19 - Cycle Period5 (in hours)	2	UI
PV 20, 21 & 22 - End date for Duration5 (Day, Month, Year)	3 * 1	3 * UC
PM 0 - Number of requested Profiles	1	UC
PM 1 - Delay before mission	2	UI
PM 2 - Reference Day	1	UC
PM 3 - Day for 1 st profile surfacing	1	UC
PM 4 - Estimated Hour on Surface	1	UC
PM 5 - 1 st Parking Depth (Bar)	2	UI
PM 6 - 1 st Profile Depth (Bar)	2	UI
PM 7 - Transmission	1	UC
2nd to 9th Day for surfacing + Hour + Pdrift + Pprofile + Transmission	(1+1+2+2+1) * 8	
PM 48 - 10 th profile Surfacing day	1	UC
PM 49 - 10 th Profile Surfacing hour	1	UC
PM 50 - 10 th Parking Depth (Bar)	2	UC
PM 51 - 10 th Profile Depth (Bar)	2	UC
PM 52 - 10 th Transmission	1	UC
Not Used (filled with zeros)	27	

With firmware V3.00 and higher

data	Format (bytes)	Format (coding)
<u>Packet Type: 255</u>	1	UC
Packet Date/Hour (Day, month, Year, hour, minute, second)	6*1	6 * UC
Cycle Number	2	UI

Profile Number	1	UC
Remote control received	1	UC
Remote control rejected	1	UC
PV 0 - Number of different cycle durations (1 to 5)	1	UC
PV 1 - Iridium End Of Life Period(min)	2	UI
PV 2 - Iridium 2 nd session waiting time (min)	1	UC
PV 3 - Cycle Period1 (in hours)	2	UI
PV 4,5 &6 - End date for Duration1 (Day, Month, Year)	3 * 1	3 * UC
PM 0 - Number of requested Profiles	1	UC
PM 1 - Delay before mission	2	UI
PM 2 - Reference Day	1	UC
PM 3 - Day for 1 st profile surfacing	1	UC
PM 4 - Estimated Hour on Surface	1	UC
PM 5 - 1 st Parking Depth (Bar)	2	UI
PM 6 - 1 st Profile Depth (Bar)	2	UI
PM 7 - Transmission	1	UC
2nd to 9th Day for surfacing + Hour + Pdrift + Pprofile + Transmission	(1+1+2+2+1) * 8	
PM 48 - 10 th profile Surfacing day	1	UC
PM 49 - 10 th Profile Surfacing hour	1	UC
PM 50 - 10 th Parking Depth (Bar)	2	UC
PM 51 - 10 th Profile Depth (Bar)	2	UC
PM 52 - 10 th Transmission	1	UC
Not Used (filled with zeros)	45	
Total	140	

7.3.4.10 Packet Type 254 (Technical parameters)

Data	Format (bytes)	Format (coding)
<u>Packet Type: 254</u>	1	UC
Packet Date & Hour (Day, Month, Year, Hour, Minute, Second)	6*1	6 * UC
Cycle number	2	UI
Profile Number	1	UC
PT 0 - Max eV activation on Surface (in csec)	2	UC
PT 1 - Number of Valve activations target	2	UI
PT 2 - Pressure timing period during buoyancy reduction	2	UI
PT 3 - Pressure timing period during ascent (in min)	2	UI
PT 4 - Max volume eV during descent and repositioning	2	UI
PT 5 - Max duration pump during repositioning (in csec)	2	UI
PT 6 - Duration pump during ascent (in csec)	2	UI
PT 7 - Duration Pump during for surfacing (in csec)	2	UI
PT 8 - Pressure Delta for positioning (in dBars)	2	UI
PT 9 - Max pressure before emergency ascent (in dBars)	2	UI

PT 10 - 1 st threshold for buoyancy reduction (in dBars)	2	UI
PT 11 - 2 nd threshold for buoyancy reduction (in dBars)	2	UI
PT 12 - Repositioning threshold (in dBars)	2	UI
PT 13 - Grounding mode (0 = pressure switch, 1 stay grounded)	2	UI
PT 14 - Max volume before detecting grounding (in cm3)	2	UI
PT 15 - Grounding pressure (in dBars)	2	UI
PT 16 - Grounding switch pressure (in dBars)	2	UI
PT 17 - Pressure delta during drift (in dBars)	2	UI
PT 18 - Average descent speed (in mm/sec)	2	UI
PT 19 - Pressure increment (in dBars)	2	UI
PT 20 - Time-out modem Iridium (in min)	2	UI
PT 21 - Min ascent speed (in mm/sec)	2	UI
PT 22 - Average ascent speed (in mm/sec)	2	UI
PT23 - Wait period on surface after Emergency ascent (in min)	2	UI
PT24 - Volume to transfer after Buyoancy reduction phase (in cm3)	2	UI
PT25 - Iridium Retries	2	UI
PT 26 - Coef 1	2	UI
PT 27 - Coef 2	2	UI
Not used (filled with zeros)	74	
Total	140	

With firmware V3.00 and higher

Data	Format (bytes)	Format (coding)
<u>Packet Type</u> : 254	1	UC
Packet Date & Hour (Day, Month, Year, Hour, Minute, Second)	6*1	6 * UC
Cycle number	2	UI
Profile Number	1	UC
PT 0 - Max eV activation on Surface (in csec)	2	UC
PT 1 - Number of Valve activations target	2	UI
PT 2 - Pressure timing period during buoyancy reduction	2	UI
PT 3 - Pressure timing period during ascent (in min)	2	UI
PT 4 - Max volume eV during descent and repositioning	2	UI
PT 5 - Max duration pump during repositioning (in csec)	2	UI
PT 6 - Duration pump during ascent (in csec)	2	UI
PT 7 - Duration Pump during for surfacing (in csec)	2	UI
PT 8 - Pressure Delta for positioning (in dBars)	2	UI
PT 9 - Max pressure before emergency ascent (in dBars)	2	UI
PT 10 - 1 st threshold for buoyancy reduction (in dBars)	2	UI
PT 11 - 2 nd threshold for buoyancy reduction (in dBars)	2	UI
PT 12 - Repositioning threshold (in dBars)	2	UI
PT 13 - Grounding mode (0 = pressure switch, 1 stay	2	UI

grounded)		
PT 14 - Max volume before detecting grounding (in cm3)	2	UI
PT 15 - Grounding pressure (in dBars)	2	UI
PT 16 - Grounding switch pressure (in dBars)	2	UI
PT 17 - Pressure delta during drift (in dBars)	2	UI
PT 18 - Average descent speed (in mm/sec)	2	UI
PT 19 - Min ascent speed (in mm/sec)	2	UI
PT 20 - Average ascent speed (in mm/sec)	2	UI
PT 21 - Wait period on surface after Emergency ascent (in min)	2	UI
PT 22 - Volume to transfer after Buoyancy reduction phase (in cm3)	2	UI
PT 23 - Number of retries per SBD commands on error	2	UI
PT 24 - Buoyancy inversion : Offset pressure	2	UI
PT 25 - Buoyancy inversion : Volume of first EV activation	2	UI
PT 26 - Buoyancy inversion : Volume of next EV activation	2	UI
PT 27 - Buoyancy inversion : Maximum volume of EV activation	2	UI
PT 28 – Coef 1	2	UI
PT 29 – Coef 2	2	UI
ICE PARAMETERS		
PG 0 - Ice detection : Nb day without emergence	2	UI
PG 1 - Ice detection : Nb day before forcing an emergence	2	UI
PG 2 - Algo ISA : Nb of ISA detections before ice confirmation	2	UI
PG 3 - Algo ISA : Threshold pressure of deceleration	2	UI
PG 4 - Algo ISA : Scrutation delay of speed	2	UI
PG 5 - Algo ISA : Minimum speed	2	UI
PG 6 - Algo ISA : Pump activation delay	2	UI
PG 7 - Satellite mask : GPS session timeout to consider a masking	2	UI
PG 8 - Ascent hanging : Pump volume to consider an hanging on ascent	2	UI
Not used (filled with zeros)	52	
Total	140	

7.3.4.11 Packet Type 248 (RUDICS parameters)

With firmware V3.00 and higher

Data	Format (bytes)	Format (coding)
<u>Packet Type: 248</u>	1	UC
Packet Date & Hour (Day, Month, Year, Hour, Minute, Second)	6*1	6 * UC
Cycle number	2	UI
Profile Number	1	UC
PI 3 - Session Time-out (in minutes)	2	UC
PI 4 - First hanging Time-out (in minutes)	2	UI

PI 5 - Full Auto-test (Rudics server connection test at mission begin)	1	UC
PI 6 - SBD positioning activation	1	UC
PI 7 - Send SBD positioning only on GPS default	1	UC

7.3.4.12 Packet Type 253 (Vector Technical data)

Data	Format (bytes)	Format (coding)
General Information		
<u>Packet Type : 253</u>		
Float's time (Year, Month, Day, Hour, Minute, Second)	6	6 * UC
Float serial number	2	UI
Total number of profile	2	UI
Cycle number	2	UI
Profile Number	1	UC
Cycle Start Day (relative to mission start Day)	2	UI
Cycle Start Hour (resolution : 1 minute)	2	UI
Phase	1	UC
Sensor Board Dialog error (count)	2	UI
TimeOut FP (count)	2	UI
Internal Vacuum (modulo 5mbar, 5mbar resolution)	1	UC
Battery Voltage (Voltage dropout from 15V, resolution : 0.1V)	1	UC
RTC State	1	UC
Buoyancy Reduction		
Buoyancy Reduction Start Day (relative to mission start Day)	2	UI
Buoyancy Reduction Start Hour (resolution : 1 minute)	2	UI
Ev Timing opening (in minutes)	1	UC
number of valve actions at the surface	1	UC
Descent to parking Depth		
Parking Descent Start Day (relative to mission start)	2	UI
Parking Descent Start Hour (resolution : 1 minute)	2	UI
float stabilisation Day (relative to mission start)	2	UI
float stabilisation Hour (resolution : 1 minute)	2	UI
Parking Descent End Day (relative to mission start)	2	UI
Parking Descent End Hour (resolution : 1 minute)	2	UI
number of valve actions in descent	1	UC
number of pump actions in descent	1	UC
float stabilisation pressure (Resolution 1 Bar)	1	UC
Max pressure during descent to parking depth (Res : 1 Bar)	1	UC
Parking Drift Phase		
number of entrance in drift target range (descent)	1	UC
number of repositions	1	UC
minimum pressure in drift to parking depth (Res : 1 Bar)	1	UC
maximum pressure in drift to parking depth (Res : 1 Bar)	1	UC
number of valve actions in parking	1	UC
number of pump actions in parking	1	UC
Descent To Profile Depth		
Profile Descent Start Day (relative to mission start)	2	UI
Profile Descent Start Hour (resolution : 1 minute)	2	UI
Profile Descent End Day (relative to mission start)	2	UI
Profile Descent End Hour (resolution : 1 minute)	2	UI
number of valve actions in descent	1	UC
number of pump actions in descent	1	UC
max pressure in descent to Pprofile (Res : 1 Bar)	1	UC
Profile Drift Phase		

number of entrance in profile drift target range	1	UC
number of re-positioning in profile stand-by	1	UC
number of valve actions in drift at Profile depth	1	UC
number of pump actions in drift at Profile depth	1	UC
minimum pressure in drift to Pprofile (Res : 1 Bar)	1	UC
maximum pressure in drift to Pprofile(Res : 1 Bar)	1	UC
Ascent Phase		
Profile Ascent Start Day (relative to mission start)	2	UI
Profile Ascent Start Hour (resolution : 1 minute)	2	UI
Profile Ascent End Day (relative to mission start)	2	UI
Profile Ascent End Hour (resolution : 1 minute)	2	UI
number of pump actions in ascent	1	UC
First Grounding Information		
grounding detected (grounding = 1, No grounding = 0)	1	UC
Grounding pressure (Res : 1 Bar)	1	UC
First grounding day relative to mission start	2	UI
Hour at grounding (resolution : 1 minute)	2	UI
Emergency Ascent Phase		
Emergency ascent number	1	UC
1 st Emergency ascent time (resolution : 1 minute)	2	UI
1 st Emergency pressure (Res : Bar)	1	UC
number of pump actions in first emergency ascent	1	UC
1 st Emergency ascent relative day (to 1 st cycle day)	1	UC
Iridium Remote Control		
Remote control received	1	UC
Remote control rejected	1	UC
GPS Data		
GPS latitude in degrees	1	UC
GPS latitude in minutes	1	UC
GPS latitude in minutes fractions (1/10000)	2	UI
GPS latitude orientation (0= North, 1 = South)	1	UC
GPS longitude in degrees	1	UC
GPS longitude in minutes	1	UC
GPS longitude in minutes fractions (1/10000)	2	UI
GPS longitude orientation (0= East, 1 = West)	1	UC
GPS valid fix (1 = valid, 0 = not valid)	1	UC
Show mode Vector Board (0 : not active ; 1 active)	1	UC
Show mode Sensor Board (0 :not active ; 1 active)	1	UC
Sensor Board Status :		
- Bit0 : PowerOn reset	4	ULI
- Bit1 : External reset		
- Bit2 : BrownOut reset		
- Bit3 : WatchDog reset		
- Bit4 : JTAG reset		
- Bit5 : Read RTC error		
- Bit6 : Write RTC error		
- Bit7 : Config RTC alarm error		
- Bit8 : Flash1 Initialization error		
- Bit9 : Flash1 PowerDown error		
- Bit10 : Flash2 Initialization error		
- Bit11 : Flash2 PowerDown error		
- Bit 12 to 31 : Not used		
Number of Rudics session Time-out		
Nb of errors during rudics session		
Vector firmware checksum		
Measure firmware checksum		
Previous rudcis session duration		
GPS Fix delay		

Auotest Result		
- Bit0 : EEPROM error		
- Bit1 : FLASH error		
- Bit2 : Internal vaccum error		
- Bit3 : Battery voltage error		
- Bit4 : External bladder filling error		
- Bit5 : Sensor board error		
- Bit6 : Modem communication error		
- Bit7 : GPS error		
- Bit8 : RUDICS server connection error		
Factory diagnostic		
Free (filled with zeros)	2	
TOTAL	140	

With firmware V3.00 and higher

Data	Format (bytes)	Format (coding)
General Information		
<u>Packet Type : 253</u>	1	UC
Float's time (Year, Month, Day, Hour, Minute, Second)	6	6 * UC
Float serial number	2	UI
Total number of profile	2	UI
Cycle number	2	UI
Profile Number	1	UC
Cycle Start Day (relative to mission start Day)	2	UI
Cycle Start Hour (resolution : 1 minute)	2	UI
Phase	1	UC
Sensor Board Dialog error (count)	2	UI
TimeOut FP (count)	2	UI
Internal Vacuum (modulo 5mbar, 5mbar resolution)	1	UC
Battery Voltage (Voltage dropout from 15V, resolution : 0.1V)	1	UC
RTC State	1	UC
Buoyancy Reduction		
Buoyancy Reduction Start Day (relative to mission start Day)	2	UI
Buoyancy Reduction Start Hour (resolution : 1 minute)	2	UI
Cumulative valve actions at the surface	1	UC
Additional valve actions at the surface	1	UC
Buoyancy Inversion		
Buoyancy Inversion Start Day (relative to mission start Day)	2	UI
Buoyancy Inversion Start Hour (resolution : 1 minute)	2	UI
Number of valve actions	1	UC
Descent to parking Depth		
Parking Descent Start Day (relative to mission start)	2	UI
Parking Descent Start Hour (resolution : 1 minute)	2	UI
float stabilisation Day (relative to mission start)	2	UI
float stabilisation Hour (resolution : 1 minute)	2	UI
Parking Descent End Day (relative to mission start)	2	UI
Parking Descent End Hour (resolution : 1 minute)	2	UI
number of valve actions in descent	1	UC
number of pump actions in descent	1	UC
float stabilisation pressure (Resolution 1 Bar)	1	UC
Max pressure during descent to parking depth (Res : 1 Bar)	1	UC
Parking Drift Phase		
number of entrance in drift target range (descent)	1	UC
number of repositions	1	UC
minimum pressure in drift to parking depth (Res : 1 Bar)	1	UC

maximum pressure in drift to parking depth (Res : 1 Bar)	1	UC
number of valve actions in parking	1	UC
number of pump actions in parking	1	UC
Descent To Profile Depth		
Profile Descent Start Day (relative to mission start)	2	UI
Profile Descent Start Hour (resolution : 1 minute)	2	UI
Profile Descent End Day (relative to mission start)	2	UI
Profile Descent End Hour (resolution : 1 minute)	2	UI
number of valve actions in descent	1	UC
number of pump actions in descent	1	UC
max pressure in descent to Pprofile (Res : 1 Bar)	1	UC
Profile Drift Phase		
number of entrance in profile drift target range	1	UC
number of re-positioning in profile stand-by	1	UC
number of valve actions in drift at Profile depth	1	UC
number of pump actions in drift at Profile depth	1	UC
minimum pressure in drift to Pprofile (Res : 1 Bar)	1	UC
maximum pressure in drift to Pprofile(Res : 1 Bar)	1	UC
Ascent Phase		
Profile Ascent Start Day (relative to mission start)	2	UI
Profile Ascent Start Hour (resolution : 1 minute)	2	UI
Profile Ascent End Day (relative to mission start)	2	UI
Profile Ascent End Hour (resolution : 1 minute)	2	UI
number of pump actions in ascent	1	UC
Ice detection flags (ISA detection : Bit 0, Satellite mask : Bit 1, Ascent hanging : Bit 2, ISA table overflow : Bit 7)	1	UC
First Grounding Information		
grounding detected (grounding = 1, No grounding = 0)	1	UC
Grounding pressure (Res : 1 Bar)	1	UC
First grounding day relative to mission start	2	UI
Hour at grounding (resolution : 1 minute)	2	UI
Hanging information		
Hanging detected (hanging = 1, No hanging = 0)	1	UC
Hanging pressure (Res : 1 Bar)	1	UC
First hanging day relative to mission start	2	UI
Hour at hanging (resolution : 1 minute)	2	UI
Emergency Ascent Phase		
Emergency ascent number	1	UC
1 st Emergency ascent time (resolution : 1 minute)	2	UI
1 st Emergency pressure (Res : Bar)	1	UC
number of pump actions in first emergency ascent	1	UC
1 st Emergency ascent relative day (to 1 st cycle day)	1	UC
Iridium Remote Control (Rev11)		
Remote control received	4	UC
Remote control rejected	4	UC
GPS Data		
GPS latitude in degrees	1	UC
GPS latitude in minutes	1	UC
GPS latitude in minutes fractions (1/10000)	2	UI
GPS latitude orientation (0= North, 1 = South)	1	UC
GPS longitude in degrees	1	UC
GPS longitude in minutes	1	UC
GPS longitude in minutes fractions (1/10000)	2	UI
GPS longitude orientation (0= East, 1 = West)	1	UC

GPS valid fix (1 = valid, 0 = not valid)	1	UC
Show mode Vector Board (0 : not active ; 1 active)	1	UC
Show mode Sensor Board (0 :not active ; 1 active)	1	UC
Sensor Board Status :		
- Bit0 : PowerOn reset	4	ULI
- Bit1 : External reset		
- Bit2 : BrownOut reset		
- Bit3 : WatchDog reset		
- Bit4 : JTAG reset		
- Bit5 : Read RTC error		
- Bit6 : Write RTC error		
- Bit7 : Config RTC alarm error		
- Bit8 : Flash1 Initialization error		
- Bit9 : Flash1 PowerDown error		
- Bit10 : Flash2 Initialization error		
- Bit11 : Flash2 PowerDown error		
- Bit 12 to 31 : Not used		
RUDICS Information		
Number of Rudics session Time-out	1	UC
Nb of errors during rudics session	2	UI
Session Information		
Iridium delay of previous session	2	UI
GPS Fix delay of current session	2	UI
Firmware Information		
Vector firmware checksum	2	UI
Measure firmware checksum	2	UI
Autotest Information		
Autotest Result		
- Bit0 : EEPROM error	2	UI
- Bit1 : FLASH error		
- Bit2 : Internal vaccum error		
- Bit3 : Battery voltage error		
- Bit4 : External bladder filling error		
- Bit5 : Sensor board error		
- Bit6 : Modem communication error		
- Bit7 : GPS error		
- Bit8 : RUDICS server connection error		
Factory diagnostic / Free (filled with zeros)	6	
TOTAL	140	

- One technical packet per profile. In case of « multi profile » Cycle without transmission, several technical packet will be generated and transmitted.
- Float's Time is coded with 6 bytes : year (1byte) + month (1 byte) + day (1byte) hour (1 byte) + minute (1 byte) + second (1 byte).

7.3.4.13 Packet Type 252 (Pressure Packet)

Data	Format (bytes)	Format (coding)
<u>Packet Type: 252</u>	1	UC
Cycle Number	2	UI
Phase & Profile Number (*) (Sample 1)	1	UC
Pump or ev (0 = eV, 1 = Pump) (Sample 1)	1	UC
Activation Pressure (Bars) (Sample 1)	1	UC
Relative Time (minutes / phase start) (Sample 1)	2	UI
Sample 2 to 27	(1+1+1+2) * 26	
Not used (filled with zeros)	2	
Total	140	

(*) : Phase is coded on the 4first bits, Profile number with the last 4 bits

With firmware V3.00 and higher

Data	Format (bytes)	Format (coding)
<u>Packet Type: 252</u>	1	UC
Cycle Number	2	UI
Phase (Sample 1)	1	UC
Profile Number & "Pump or ev" (0 = eV, 1 = Pump) (Sample 1) (**)	1	UC
Activation Pressure (Bars) (Sample 1)	1	UC
Relative Time (minutes / phase start) (Sample 1)	2	UI
Activation delay (csec)	2	UI
Sample 2 to 19	(1+1+1+2+2) * 18	
Not used (filled with zeros)	4	
Total	140	

(**) : Profile number is coded on the 4first bits, Action type with the last 4 bits

NB : Hydraulic actions in Buoyancy reduction are not included in this packet

7.3.4.14 Packet Type 251 (Sensor Parameters)

Only modified parameters since last Iridium session, are transmitted.

Data	Format (bytes)	Format (coding)
Packet Type: 251	1	UC
1 st number of modified Sensor	1	UC
1 st Parameter Type (0 : Standard 1 : Specific)	1	UC
1 st Parameter Number	1	UC
1 st Old value	4	FLOAT
1 st New value	4	FLOAT
2nd to12th modified sensor number + parameter type + parameter number + old value + New value	(1+1+1+4+4) * 11	
Not used (filled with zeros)	7	
Total	140	

7.3.4.15 Packet Type 249 (Sensor Parameters)

With firmware V3.00 and higher

Standard parameters :

Data	Format (bytes)	Format (coding)
Packet Type: 249	1	UC
Sensor number (6 bits) (0:CTD, 1:DO...) + Parameter Type (2 bits) (0: standard parameters)	1	UC
Cycle number	2	UI
Profile number	1	UC
Phase Number	1	UC
Sample Date & Hour	4	ULI
1 st of 48 th standard parameters	(48) * 2	UI
Not used (filled with zeros)	32	UC
Total	140	

Specific parameters :

Data	Format (bytes)	Format (coding)
Packet Type: 249	1	UC
Sensor number (6 bits) (0:CTD, 1:DO...) + Parameter Type (2 bits) (1 :specific parameters)	1	UC
Cycle number	2	UI
Profile number	1	UC
Phase Number	1	UC
Sample Date & Hour	4	ULI
1 st of xx th specifics parameters (xx : different for each sensor)	xx * 4	FLOAT
Not used (filled with zeros)		UC
Total	140	

7.3.4.16 Packet Type 250 (Sensor Technical Data)

Data	Format (bytes)	Format (coding)
General information		
Packet Type: 250	1	UC
Data Type : « X » (*)	1	UC
Cycle number	2	UI
Profile Number	1	UC
Type X transmitted Data		
Packet Number for « X » Type in descent	1	UC
Packet Number for « X » Type in drift	1	UC
Packet Number for « X » Type in ascent	1	UC
Type X acquired Data		
Descent, nb points zone 1	1	UC
Descent, nb points zone 2	1	UC
Descent, nb points zone 3	1	UC
Descent, nb points zone 4	1	UC
Descent, nb points zone 5	1	UC
Nb points in Drift	1	UC
Ascent, nb points zone 1	1	UC
Ascent, nb points zone 2	1	UC
Ascent, nb points zone 3	1	UC
Ascent, nb points zone 4	1	UC
Ascent, nb points zone 5	1	UC
X type Status Sensor (1 : normal, 0 if pb)	1	UC
Free Zone (specific to each sensor) (**)	50	
TOTAL	70	

Two “70 bytes packet” are included in “one140 bytes packet” that is elementary packet Float transmit “Sensor technical packet” for all sensor mounted on float. To set one sensor as mounted on float, user must set at minimum one sampling period (standard PC) as different from zero.

If all sampling period (standard PC) are equal to zero (for each sensor), it means that sensor is not mounted on float. In that case, sensor is not acquired during auto-test and during mission.

If number of sensor mounted on float is odd/even, 2nd half of packet will filled with 0x00 and 0x1A (packet type with a value : 26) for firmware V3.00 and higher

(*) Data Type

Sensor	Data Type
CTD	0

Optode	1
OCR504	2
ECO	3
FLNTU	4
cROVER7	5
SUNA	6

Free zone details by sensor ()**

N.B : Attention : Sensor information inside « free zone » are coded in « Little Endian » (***)

Free zone « CTD Data »	Format (bytes)	Format (coding)
Offset Pressure (Surface)	4	FLOAT (***)
Pressure « Subsurface »	4	FLOAT (***)
Temperature « Subsurface »	4	FLOAT (***)
Salinity « Subsurface »	4	FLOAT (***)
Free	34	
TOTAL	50	

Free zone « Optode Data »	Format (bytes)	Format (coding)
Free	50	
TOTAL	50	

Free zone « OCR504 Data »	Format (bytes)	Format (coding)
Sensor Serial number	2	UI(***)
Coefficient a0 (lambda1)	4	FLOAT (***)
Coefficient a1 (lambda1)	4	FLOAT (***)
Coefficient Im (lambda1)	4	FLOAT (***)
Coefficient a0 (lambda2)	4	FLOAT (***)
Coefficient a1 (lambda2)	4	FLOAT (***)
Coefficient Im (lambda2)	4	FLOAT (***)
Coefficient a0 (lambda3)	4	FLOAT (***)
Coefficient a1 (lambda3)	4	FLOAT (***)

Coefficient Im (lambda3)	4	FLOAT (***)
Coefficient a0 (PAR)	4	FLOAT (***)
Coefficient a1 (PAR)	4	FLOAT (***)
Coefficient Im (PAR)	4	FLOAT (***)
Free	0	
TOTAL	50	

Free zone « ECO Data »	Format (bytes)	Format (coding)
Sensor Serial number	2	UI (***)
Coefficient Scale factor Chlorophyll A	4	FLOAT (***)
Coefficient Dark count Chlorophyll A	2	UI (***)
Coefficient Scale factor Backscatter	4	FLOAT (***)
Coefficient Dark count Backscatter	2	UI (***)
Coefficient Scale factor CDOM	4	FLOAT (***)
Coefficient Dark count CDOM	2	UI (***)
Free	30	
TOTAL	50	

Free zone « FLNTU Data »	Format (bytes)	Format (coding)
Coefficient Scale factor Chlorophyll	4	FLOAT (***)
Coefficient Dark count Chlorophyll	2	UI (***)
Coefficient Scale factor Turbidity	4	FLOAT (***)
Coefficient Dark count Turbidity	2	UI (***)
Free	38	
TOTAL	50	

Free zone « cRover Data »	Format (bytes)	Format (coding)
Sensor Serial number	2	UI (***)
Free	48	
TOTAL	50	

Free zone « SUNA Data »	Format (bytes)	Format (coding)
Sensor Serial number	2	UI (***)
APF Frame : Sample Counter	4	ULI (***)
APF Frame : Power Cycle Counter	4	ULI (***)
APF Frame : Error Counter	4	ULI (***)
APF Frame : Supply Voltage	4	FLOAT (***)
APF Frame : Supply Current	4	FLOAT (***)
APF Frame : Output Pixel Begin	2	UI (***)

APF Frame : Output Pixel End	2	UI (***)
Free	24	
TOTAL	50	

With firmware V3.00 and higher

Free zone « Optode Data »	Format (bytes)	Format (coding)
Sensor Serial number	2	UI (***)
Free	48	
TOTAL	50	

The OCR sensor send 2 technical packets :

Free zone « OCR504 Data »	Format (bytes)	Format (coding)
Sensor Serial number	2	UI (***)
Coef of Sensor : 1	1	UC
Coefficient a0 (lambda1)	8	DOUBLE (***)
Coefficient a1 (lambda1)	8	DOUBLE (***)
Coefficient Im (lambda1)	4	FLOAT (***)
Coef of Sensor : 2	1	UC
Coefficient a0 (lambda2)	8	DOUBLE (***)
Coefficient a1 (lambda2)	8	DOUBLE (***)
Coefficient Im (lambda2)	4	FLOAT (***)
Free	2	

Free zone « OCR504 Data »	Format (bytes)	Format (coding)
Sensor Serial number	2	UI (***)
Coef of Sensor : 3	1	UC
Coefficient a0 (lambda3)	8	DOUBLE (***)
Coefficient a1 (lambda3)	8	DOUBLE (***)
Coefficient Im (lambda3)	4	FLOAT (***)
Coef of Sensor : 4	1	UC
Coefficient a0 (lambda4)	8	DOUBLE (***)
Coefficient a1 (lambda4)	8	DOUBLE (***)
Coefficient Im (lambda4)	4	FLOAT (***)
Free	2	

7.4 Life Expiry Messages

Life expiry messages are transmitted when the float is drifting on the surface and has completed transmission of all data from the last cycle of the Mission. Life Expiry mode continues until the recovery of the float, depletion of the battery, or telecommand sending for new mission beginning.

These transmissions - unlike other transmissions - occur at "PV1" minutes intervals (Vector parameter n° 1). The content of the life expiry message is identical to the technical message.

7.5 Packet transmitting sequence (Iridium session)

After each surfacing, the float, starts a transmission phase which begins with a GPS acquisition (set of RTC clock and acquisition of a GPS fix).

It then transmits all the data collected since its last surface transmission (i.e. corresponding to one or several profiles depending on profile transmission request set with PM parameters).

The transmitted messages are the following:

Sensor measurement data:

- sensor measurements (type 0); the number of messages depends on the amount of data to transmit (it is provided in the associated message type 250)

Technical data:

- one sensor technical packet (type 250) per sensor
- one float technical packet (type 253)
- pressure packets (type 252), the number of packets depends on the recorded hydraulic activations to transmit

Configuration information:

- 251, 254 and 255 packet types to transmit parameters

During the second Iridium session (done when $PV2 > 0$), only configuration information and the float technical packet (only for the updated GPS fix) are transmitted.

7.6 Iridium commands

Each parameter (PM, PV, PC, PT, PG and some PI) can be modified by sending an Iridium telecommand to the float.

PC modified parameter are immediately taken into account, other parameter modification will be considered for the next cycle of the float's mission. Modified values are sent back by the float through 255, 254 and 251 message types. Several parameter can be modified with one telecommand. Several telecommands can be send for one cycle.

7.6.1 Command Sending procedure (SBD MODE)

To send a telecommand to float in order to modify a mission parameter, User need to send an email with attached file containing text command

For example, to modify mission parameter 5 (drift pressure for 1st profile) from 1000 to 1050, user need :

- 1- to create an empty text file (with notepad or wordpad for example)
- 2- to type same command as command send to float with hyperterminal. In our example, user need to type in file : !PM 5 1050 followed by carriage return
- 3- save file as "PM5_1050.txt"
- 4- close file
- 5- change file extension from ".txt" to ".sbd"

Once file is created, User must send email to Iridium system, with attached file.

- 6- Create an empty mail
- 7- In message subject, user must indicate float IMEI number (number only no other characters)
Be careful to indicate the right IMEI number in order not to send telecommand to another Iridium receiver or float)
- 8- Email address is : Data@SBD.IRIDIUM.com
- 9- Attached file name "PM5_1050.sbd"

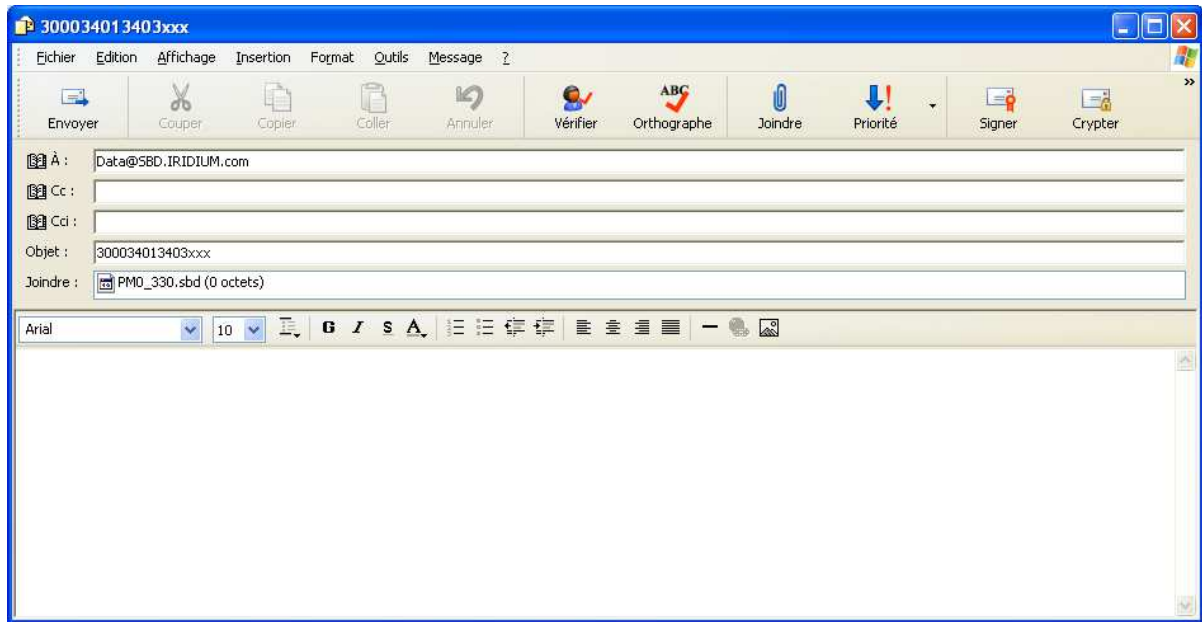

Example of mail send to iridium system

10- Send mail

11- In a delay of a few minutes, user can check that iridium system send confirmation that message is queued (email coming from sbdservice@sbd.iridium.com with subject : "SBD Mobile Terminated Message Queued for Unit : xxxxxxxxxxxxxxxx (here xx replace IMEI number)

Mail from iridium will indicate :

“

The following mobile-terminated message was queued for delivery:

IMEI: 300034013403xxx

Time: Thu Apr 29 12:00:13 2010

Attachment Filename: PM5_1050.sbd

Attachment Size: 10

The MTMSN is 2, and the message is number 1 in the queue.

“

At this step, message is queued and ready to be treated by float at next float surfacing.

Several command can be included in file. In that case do not forget to type carriage return after last command

Important : Telecommand file size must be less than 260 bytes

8 SPECIFICATIONS

- Storage
 - Temperature range..... -20°C to +50°C
 - Storage time before expiryup to 1 year
- Operational
 - Temperature range..... 0°C to +40°C
 - Pressure at drift depth 40 bar to 200 bar
 - Depth maintenance accuracy ± 3 bar typical (adjustable)
 - Survival at seaup to 4 years
 - Maximum number of cycles.....up to 255 cycles
- Mechanical
 - Length
 - with antenna#220 cm
 - Diameter
 - casing17 cm
 - damping disk 35 cm
 - Weight46kg
 - Material..... anodized aluminum casing
- Sensors
 - Salinity
 - range..... 10 to 42 PSU
 - initial accuracy ± 0.005 PSU
 - resolution..... 0.001 PSU
 - Temperature
 - range... -3°C to +32°C
 - initial accuracy± 0.002°C
 - resolution.....0.001°C
 - Pressure
 - range... 0 bar to 2500 dbar
 - initial accuracy ± 2.4 dbar*
 - resolution.....0.1 dbar
 - Offset adjusted when surfacing
 - Oxygen
 - range... 0 bar to 500 µM/l
 - initial accuracy ±8 µM/l (if < 160 µM/l) or 5% (if >160 µM/l)
 - resolution.....< 1 µM/l

(*) offset has to be adjusted at each surfacing

9 PROVBIOII OPERATING PRINCIPLE

Movement of the float through its profile is accomplished by a pump and valve system. The pump transfers oil from the inner reservoir to the outer bladder. Oil moves back to the reservoir when the valve is opened- -driven by the difference between the float's internal and external pressures.

The float's speed of ascent oscillates. This oscillation is due to the way in which the float's controller regulates its speed. The controller, using depth measurements from the float's pressure sensor, calculates the change in depth over a set period of time. With this information, the controller determines the float's speed.

When ascending, if the calculated speed is lower than desired, the pump is activated for about 10 seconds, pumping oil into the outer bladder. This produces an increase in buoyancy, which increases the speed of ascent.

As the float rises to shallower depths, its buoyancy decreases, causing the ascent speed to also decrease. When the calculated speed is too low, the pump is activated again.

This cycle repeats until the float reaches the surface.

The same regulating method is used to control the float's descent speed, by opening the valve and allowing oil to flow from the external bladder to the internal reservoir.

Why does ProvBioll 's speed decrease as it ascends?

The buoyancy of a float is determined principally by its mass and its volume, but another factor, hull compressibility, also plays an important role. As ProvBioll ascends, the decrease in water density reduces the float's buoyancy. At the same time, the decrease in water pressure causes ProvBioll 's hull to expand, which increases the float's buoyancy. The two effects tend to counteract each other.

Because ProvBioll 's compressibility is actually less than that of sea water, the decrease in buoyancy due to decreasing water density is greater than the increase in buoyancy due to hull expansion. This causes ProvBioll 's speed of ascent to decrease as it rises in the water column.

Conversely, as the float descends, the increasing water density increases the buoyancy more than the decreasing buoyancy from hull compressure. This causes ProvBioll 's speed of descent to slow as it goes deeper.

To reduce the probability of contact with ships, ProvBioll 's target speed during the initial stage of descent is high at shallow depths. This minimizes the time during which the float is at risk of damage.

To slow the float's descent, its controller is programmed with a series of depths at which the descent speed is halved until it reaches the target depth.

10 LITHIUM BATTERY

All batteries, both lithium batteries and batteries with other chemical elements, contain large quantities of stored energy. This is, of course, what makes them useful, but it also makes them potentially hazardous.

If correctly handled, neither alkaline nor lithium batteries present any risk to humans or the environment. Improper handling of these batteries presents potential risks to humans, but does not present an environmental risk.

The energy stored in a battery cell is stored in chemical form. Most batteries contain corrosive chemicals. These chemicals can be released if the cells are mishandled. Mishandling includes:

- short-circuiting the cells;
- (re)charging the cells;
- puncturing the cell enclosure with a sharp object;
- exposing the cell to high temperatures.

WARNING: BOTH ALKALINE AND LITHIUM BATTERIES MAY EXPLODE, PYROLIZE OR VENT IF MIS-HANDLED. DO NOT DISASSEMBLE, PUNCTURE, CRUSH, SHORT-CIRCUIT, (RE)CHARGE OR INCINERATE THE CELLS. DO NOT EXPOSE CELLS TO HIGH TEMPERATURES.

The lithium thionyl chloride cells used in ProvBioll floats incorporate sealed steel containers, warning labels and venting systems to guard against accidental release of their contents.

WARNING: IF A BATTERY SPILLS ITS CONTENTS DUE TO MISHANDLING, THE RELEASED CHEMICALS AND THEIR REACTION PRODUCTS INCLUDE CAUSTIC AND ACIDIC MATERIALS, SUCH AS HYDROCHLORIC ACID (HCL) IN THE CASE OF LITHIUM THIONYL CHLORIDE BATTERIES, AND POTASSIUM HYDROXIDE (KOH) IN THE CASE OF ALKALINE BATTERIES. THESE CHEMICALS CAN CAUSE EYE AND NOSE IRRITATION AND BURNS TO EXPOSED FLESH.

The hazard presented by these chemicals is comparable to that presented by common domestic cleaning materials like bleach, muriatic acid or oven cleaner.

Inevitably, the battery contents will eventually be released into the environment, regardless of whether the cells are deliberately dismantled or simply disintegrate due to the forces of nature. Because of their highly reactive nature, battery materials disintegrate rapidly when released into the environment. They pose no long-term environmental threat. There are no heavy metals or chronic toxins in ProvBioll 's lithium cells. Indeed, a recommended safe disposal method for thionyl chloride lithium cells is to crush them and dilute them in sufficient quantities of water.

Discharged batteries pose a greatly reduced threat, as the process of discharging them consumes the corrosive chemicals contained in them.

In summary, ProvBioll 's lithium battery poses no significant or long-term environmental threats. Any threats that they do present, are short-term threats to the safety of persons mishandling the cells. These safety threats are similar to those of other common household-use materials. These threats are reduced when the cells are discharged - and exist only if the cells are mishandled in extreme ways. These threats are the same as those presented by the alkaline cells widely used by consumers.

11 GLOSSARY

CPU

Central Processing Unit. In the context of ProvBioll , this term denotes the board that ensures the running and control of the system.

COM1, COM2.

Serial communication ports.

dBar.

1/10 bar = 1 decibar Unit of pressure used for ProvBioll. It roughly corresponds to a depth of 1m.

IFREMER

Institut Français pour la Recherche et l'Exploitation de la MER (French Institute for the Research and the Exploitation of the Sea).

Mission

The portion of ProvBioll 's life that consists of a number of repeating profiles of descent, submerged drift, ascent and data transmission.

PC

Personal Computer; IBM-PC compatible.

ProvBioll

Name given to the drifting profiler developed by **nke** and IFREMER.

RS232

Widely recognized standard for the implementation of a serial data communication link.

VT52, VT100

Video Terminal, type 52 or 100

Computer terminals developed by Digital Equipment Corporation (DEC). They are considered standard in the field.

Fabriqué par / Manufactured by



Nke Instrumentation
Z.I de KERANDRE - RUE GUTENBERG
56700 HENNEBONT - FRANCE
Telephone: +33 (0)2 97 36 10 12 Fax: +33 (0)2 97 36 55 17
Web : <http://www.nke.fr> - E-mail : info.instrumentation@nke.fr